

IMO Jaguar VXS

Torque Vector System

High-performance, Sensorless Vector Inverters

VXS20-1-EN – VXS220-1-EN (Single phase)

VXS40-3-EN – VXS400-3-EN (Three phase)

Power ratings from 0.22kW to 4kW

User's Guide

NOTE - Failure to read and comply with these instructions prior to installation and use of the inverter, may result in damage to the drive and/or driven equipment and subsequent invalidation of the warranty.



IMO JAGUAR VXS

Safety Precautions

Safety at Work

It is the responsibility of the owner, installer and user to ensure that the installation of the equipment and the way in which it is operated and maintained complies with the requirements of the Health & Safety at Work Act in the United Kingdom and other applicable legislation, regulations and codes of practice in the UK or elsewhere.

Only qualified personnel should install this equipment, after first reading and understanding the information in this publication. The installation instructions should be adhered to. Any question or doubt should be referred to IMO Precision Controls Ltd.

Operational Safety

Users and operators of the equipment must take all necessary precautions to prevent damage to equipment and especially to prevent the risk of injury to personnel working on or near the motor and the driven equipment.

The stop and start inputs should not be relied upon alone to ensure the safety of personnel. If a safety hazard could arise from the unexpected starting of the motor, an interlock mechanism should be provided to prevent the motor from running except when it is safe for it to do so.

Warnings, Cautions and Notes

‘WARNING’, ‘CAUTION’ and ‘NOTE’ paragraphs appear in the text of this instruction manual wherever they are applicable as precautionary reminders to installers and

operators.

NOTE Notes call attention to information

WARNING

Denotes operating procedures and practices which, if not correctly followed and strictly observed, may result in danger, personal injury or loss of life.

CAUTION

Denotes operating procedures and practices which, if not correctly followed and strictly observed, may result in damage to or destruction of equipment.

that is especially significant in understanding and operating the equipment.

Documentation

Every effort has been made by IMO Precision Controls Ltd to ensure that this document accurately and completely represents the *Jaguar VXS* range of inverters at the time of going to press. Information with respect to installation is necessarily generalised, and the supplier accepts no liability for contingencies over which he has no control in respect of the selection, installation and/or operation of equipment.

IMPORTANT NOTICE

The software described in this User’s Guide may not apply to earlier VXS inverters lacking the suffix ‘-EN’.

In line with IMO’s policy of continuous improvement, the contents of this document are subject to change without prior notice.

Copyright

All rights reserved. No part of this publication may be reproduced or transmitted in any form or by any means, electronic or mechanical including photocopying, recording, or by any information storage or retrieval system without the prior written permission of IMO Precision Controls Ltd.

© IMO Precision Controls Ltd 1996

Part number VXSMAN. Doc. ref. SWK VXS20-VXS400.

Issue IMO-3 Sept 1998

Contents

Safety Precautions	<i>Inside front cover</i>		
Warranty and Helplines	<i>Inside back cover</i>		
EMC and LVD Conformity		<i>Page 2</i>	
1 Inspection, Handling & Storage	2	6 Keypad Functions	16
1.1 Product Enquiries	2	6.1 Keypad	16
1.2 Inspection	2	6.2 Keypad Procedures	16
1.3 Storage Environment	2	7 Inverter Functions	21
1.4 Storage Precautions	2	7.1 Functions Data — <i>Range, Units, Resolution & Default</i>	21
1.5 Handling	2	7.2 Descriptions of Functions	26
2 Specifications	3	8 Troubleshooting	44
2.1 Output Ratings	3	8.1 Electronic Protection	44
2.2 Input Ratings	3	8.2 Trip Alarm Functions	44
2.3 Output Frequency	3	8.3 Trip Alarm Codes	44
2.4 Braking	3	8.4 Troubleshooting Flow Diagrams	45
2.5 General	3	9 Braking	55
3 Common Specifications	4	9.1 Introduction	55
3.1 Control	4	9.2 Overhauling Loads	55
3.2 Indication	5	9.3 Calculations for Braking Resistors	56
3.3 Protection	5	9.4 Minimum Braking Resistor Values	56
3.4 Operating Environment	5	9.5 Protection Circuits	57
4 Mechanical Installation	6	10 EMC, RFI and Filters	58
4.1 Handling	6	10.1 Electromagnetic Compatibility (EMC)	58
4.2 Environment	6	10.2 Single Phase RFI-FP Filter	60
4.3 Position and Materials	6	10.3 Three Phase RFI-FP Filter	61
4.4 Cooling and Ventilation	6	10.4 RF Ferrite Physical Data	62
4.5 Removable Covers and Keypad	7	11 Supplementary Data	62
4.6 Dimensions	7	11.1 Insulation Testing	62
5 Electrical Installation	10	11.2 Table of Cable Sizes and Maximum Lengths	63
5.1 Power Connection Block Diagrams	10	11.3 Table of Heat Losses	64
5.2 Power Circuits	11		
5.3 Control Circuits	12		
5.4 Terminals Functions List	14		
5.5 Control Circuits and Terminals	15		

EMC and LVD Conformity

IMO Jaguar VXS Inverters carrying the suffix -EN as part of their model number conform to EN 60 947-1:1992, Emissions to EN50081-1 and -2 and Immunity to EN50082-1 and -2, and therefore meet Directive 89/336/EEC relating to Electromagnetic Compatibility. Additionally, they also comply with DIN VDE 0160/1988 for Over Voltage Category II, Pollution Degree 2, and hence conform to the protection requirements of Council Directive 73/23/EEC, Low Voltage Directive. Conformity requires the VXS inverter to be wired and earthed in accordance with the installation instructions in this User's Guide and installed within a steel enclosure which satisfies the requirements of Pollution Degree 2 and used in conjunction with an AC power supply which is recognised Over Voltage Category II and has an earthed neutral point. Throughout this manual the -EN suffix has been omitted for simplicity and for economy of space.

Earth terminals. Jaguar VXS... -EN inverters now carry the standard symbol  instead of the lettering 'GND(PE)'.

1 Inspection, Handling and Storage

1.1 Product Enquiries

If at any time you have a difficulty or a question regarding the inverter, please contact IMO Precision Controls Ltd at the address inside the back cover of this Manual. The following information will be required:

- Inverter type (from the rating plate).
- Serial number (from the rating plate).
- Date of purchase.
- The nature of the problem — for instance, the location and extent of damage, the point which is unclear or the circumstances under which a malfunction occurred.

1.2 Inspection

Immediately after unpacking the inverter, please inspect as follows:

Check the rating plate on the side of the inverter cover to ensure that the inverter specification corresponds to the order specification. Inspect the inverter to determine whether the unit has been damaged in transit. Look for loose components and damage to any part of the cover, side panels, mounting brackets or other components.

1.3 Storage Environment

- Temperature -20°C to $+65^{\circ}\text{C}$ (-4°F to $+149^{\circ}\text{F}$) short-term during transport or storage.
- Relative humidity 20% to 90% non-condensing.
- Avoid places where large variations in*

temperature occur, even if the relative humidity is within the specified limits. Such places could cause condensation or freezing and should be avoided.

- The inverter should not be placed in direct sunlight. The surrounding atmosphere should ideally be dry, free from dust, corrosive or inflammable gases or vapours, oil mist, steam, dripping water and vibration. A salt-laden atmosphere is especially deleterious.

1.4 Storage Precautions

- Do not place the inverter directly onto the floor. It should always be placed on a stand or shelf.
- If the inverter is being stored in a less-than-ideal environment, cover it with a plastic sheet for protection.
- If there is a likelihood of humidity affecting the inverter, place a desiccating agent (such as silica gel) inside the inverter, and then cover it with a plastic sheet for protection.

1.5 Handling

Be sure to take a firm grip of the **chassis** of the unit when carrying the inverter.

CAUTION

Hold and lift the inverter by the chassis/heatsink, **not** by the cover. The cover is a protective shield only, and is not intended for lifting and carrying. Lifting the inverter by the cover or other front parts may result in damage.

2 Specifications

<i>Inverter type</i>	VXS...	20-1	40-1	75-1	150-1	220-1	40-3	75-3	150-3	220-3	400-3	
2.1 Output Ratings		Single-phase Input					Three-phase Input					
Nominal applied motor	kW	0.2	0.4/ 0.55	0.75	1.5	2.2	0.4/ 0.55	0.75	1.5	2.2	4.0	
Rated capacity*	kVA	0.6	1.2	2.0	3.2	4.4	1.2	1.8	2.7	4.0	6.5	
Voltage	V	0V to V_L										
Frequency	Hz	0.2Hz to 400Hz										
Rated current	<i>Low PWM freq.</i>	A	1.5	3.0	5.0	8.0	11.0	1.6	2.5	3.7	5.5	9.0
	<i>High PWM freq.</i>	A	1.3	2.5	4.0	7.0	10.0	1.4	2.1	3.7	5.3	8.7
Overload capability		150% of rated current for 1 minute 200% of rated current for 0.5s										
2.2 Input Ratings		Single-phase Input					Three-phase Input					
Rated current (rms)	A	2.95	4.1	7.2	14	20	1.3	2.2	4.3	6.0	9.8	
Min. supply capacity	kVA	0.7	1.2	1.8	3.2	4.5	0.7	1.2	2.2	3.1	5.0	
MCB rating	<i>with DC reactor</i>	A	6	6	10	10	20	6	6	6	10	10
	<i>without DC reactor</i>	A	6	10	16	20	32	6	6	10	16	16
Fuse rating	<i>with DC reactor</i>	A	10	10	20	32	40	6	6	10	10	20
	<i>without DC reactor</i>	A	10	10	20	32	40	6	6	10	10	20
Phase; Voltage V_L ; Frequency		1-ph; 200/240V; 50/60Hz					3-ph; 380/415V; 50/60Hz					
Variations	<i>Voltage</i>	+10% to -10%					+10% to -15%					
	<i>Imbalance</i>	—					Max. 3% of line to line voltage					
	<i>Frequency</i>	+5% to -5%										
2.3 Output Frequency		Single-phase Input					Three-phase Input					
Max. frequency	Hz	0.2Hz to 400Hz										
Base freq. setting range	Hz	15Hz to 400Hz										
Starting freq. setting range	Hz	0.2Hz, 1Hz to 60Hz (minimum unit 1Hz)										
Carrier freq. setting range	kHz	0.75kHz, 1kHz to 15.6kHz (minimum unit 1kHz)										
Accuracy (stability)	<i>Analog</i>	±0.2% of Maximum O/P Frequency (25°C ±10°C)										
	<i>Digital</i>	±0.01% of Maximum O/P Frequency (-10°C to +50°C)										
Setting resolution	<i>Analog</i>	1/3000 of Max. O/P Frequency eg 0.2Hz if max. is 60Hz; 0.4Hz if max. is 120Hz, etc										
	<i>Digital</i>	0.01Hz up to 99.99Hz output frequency and 0.1Hz from 100Hz output frequency upwards										
2.4 Braking		Single-phase Input					Three-phase Input					
Braking torque	<i>without resistor</i>	≥100%	≥70%	≥40%			≥100%	≥50%				
	<i>with resistor</i>	—	≥150%	≥100%			≥150%	≥100%				
DC Injection Braking		Starting frequency: 0.2Hz to 60Hz										
		Braking time: 0.01s to 30s										
		Braking level: 0 to 100% of rated current										
2.5 General		Single-phase Input					Three-phase Input					
Heat loss	<i>Please refer to data on page 64</i>											
Enclosure	IP40, all models (side covers in place)											
Cooling method	Convection					Fan-assisted	Convection					Fan-assisted
Mass	kg	1.1	1.6	1.7	2.7	2.8	1.8	1.8	2.7	2.7	3.2	

* At 230V single phase or 415V three phase.

3 Common Specifications

3.1 Control

<i>Control features</i>	PWM	Sine-weighted PWM output voltage control with dead-time compensation. Ultra-low acoustic noise realised by high-frequency carrier wave.
	Torque	<i>Torque Vector</i> control or manual torque boost with slip compensation.
	Auto-tune	Auto tuning function as standard. Enables automatic calculation of the total load values of %R and %X.
<i>Operation facilities</i>	Key Pad	RUN, STOP.
	External signal inputs	FWD, REV and coast-to-stop BX. External fault trip THR. Alarm/trip reset RST. Two- or three-wire RUN/STOP control. External selection of V/f ratio, Accel./Decel., Torque Boost and Thermal Overload for 2nd motor.
	Preset speeds	Seven preset speeds selection X1, X2, X3; 8 additional preset speeds, X4.
<i>Speed reference</i>	Key Pad	Raise and lower speed, \wedge and \vee keys.
	Potentiometer	1k Ω , 1W external control.
	Analog I/P	0 to +5V DC, 0 to +10V DC and 4-20mA DC.
	Digital I/P	'Motorised pot.', or 7 or 15 preset speeds.
<i>Serial communications</i>		RS485 optional.
<i>Voltage-dip ride-through</i>		VXS inverters can be operated continuously when the supply voltage is $\geq 165V$ (1-ph) or $\geq 310V$ (3-ph). Operating time if $< 165V$ (1-ph) or $< 310V$ (3-ph) = 15ms. Smooth recovery selectable.
<i>Run status signals</i>	Digital O/P	RUN, FDT, FAR, LU, TL, IP ⁽¹⁾ selectable outputs at terminal Y1E.
	Analog O/P	At terminal FMA, the following status signals are selectable: O/P frequency, O/P current, O/P torque %, load factor %.
	Pulse O/P	At terminal FMP, O/P frequency multiplying factor adjustable from 10 to 100.
<i>Accel/Decel</i>	Time	0.01 to 3600s. There are two independently-adjustable sets of acceleration and deceleration times.
	Characteristic	Choice of linear or two types of S-curve accel/decel pattern.
<i>Voltage/Frequency</i>	V/f	Automatic AVR control of V/f characteristic at base frequency. Output voltage at base frequency adjustable from 80V to 240V, 1-ph; 160V to 480V, 3-ph. Base frequency is selectable for two motors.
<i>Frequency</i>	Limiter	Output frequency can be held within selectable high and low limits.
	Bias	Analog frequency reference can be biased from -400Hz to +400Hz, in steps of 1Hz.
	Gain	An adjustable gain can be applied to the analog frequency reference, range to 250%.
	Skip-frequency	Three preset skip (jump) frequencies, 0 to 400Hz in steps of 1Hz. Bandwidth (hysteresis) for jump frequencies, 0 to 30Hz in steps of 1Hz.
<i>Slip compensation</i>		Selectable compensation to maintain speed when load torque changes.
<i>Auto-restart</i>		Four selectable modes of operation.
<i>Torque boost</i>	Auto	Boost adjusts automatically according to the calculated load torque value.
	Manual	31 patterns selectable as follows: Squared torque characteristic; Proportional torque characteristic; Weak linear boost... adjustable in 28 steps to... strong linear boost.

(1) FDT = Frequency detected; FAR = 'At speed' window; LU = Undervoltage protection trip operated; TL = Inverter at torque limit; IP = Inverter auto-restarted after restoration of I/P power following momentary loss.

<i>Torque boost (contin.)</i>	Starting Limit	150%+ at 1Hz. With <i>Torque Vector</i> control, 200%+ at 3Hz.
		When the motor torque reaches a preset level, the torque limit function automatically controls the output frequency to prevent the inverter from tripping due to an overload, if selected.
<i>2nd motor operation</i>		The following functions are provided for the control of a 2nd motor: Rated current 2; Base frequency 2; Torque boost 2; Acceleration time 2; Deceleration time 2; Electronic thermal overload relay 2.

3.2 Indication

<i>Operating mode</i>	The following operating parameters can be selected to view: Output frequency; Output current; Output voltage; Motor synchronous speed (rpm); Line speed (m/min).
<i>Programming mode</i>	LED display: Function number and data (refer to pages 18 to 20).
<i>Trip mode</i>	LED display: cause of trip. Refer to Function 29, page 32.

3.3 Protection

<i>Supply system surge V</i>	Protection to the following level: 1.2 x 50 μ s, 7kV peak.
<i>Overload trip</i>	Selectable electronic thermal overload relay protecting the power output IGBTs.
<i>Overvoltage trip</i>	Detection of overvoltage in the DC bus circuit at the following levels: <i>Single phase inverters:</i> 400V DC. <i>Three phase inverters:</i> 800V DC.
<i>Undervoltage trip</i>	Detection of undervoltage in the DC bus circuit at the following levels: <i>Single phase inverters:</i> 200V DC. <i>Three phase inverters:</i> 400V DC.
<i>Overtemperature trip</i>	Temperature detection of inverter hardware.
<i>Output short circuit trip</i>	Inverter output circuit, factory-set short circuit protection.
<i>Earth (ground) fault trip</i>	Inverter output circuit, factory-set earth fault protection.
<i>Motor thermal O/L trip</i>	Internal electronic thermal overload, user-selectable for application. The second unit of this function is available for a 2nd motor.
<i>Stall prevention</i>	Prevents the inverter tripping on overcurrent when the output current exceeds a preset limiting level during acceleration, deceleration, or at steady speed by freezing or reducing the output frequency.
<i>Alarm output</i>	Changeover contacts operate when a protective function is activated. Rating: 48V DC, 0.3A.
<i>Alarm reset</i>	Alarm cancelled by either RESET keypad key or terminal RST.
<i>Alarm history</i>	The last four alarms are recorded and can be viewed. Refer to Function 29, page 32.

3.4 Operating Environment

<i>Altitude</i>	Derate the inverter if installed above 1000m (3280ft).
<i>Location</i>	The inverter is designed for installation in a steel enclosure. Do not install the inverter in a dusty location or expose to corrosive gases, oil or water, or direct sunlight.
<i>Ambient temperature</i>	-10 $^{\circ}$ C to +50 $^{\circ}$ C (+14 $^{\circ}$ F to +122 $^{\circ}$ F). If ambient temperature exceeds 40 $^{\circ}$ C (104 $^{\circ}$ F), remove inverter side covers.
<i>Ambient humidity</i>	20% to 90% non-condensing.
<i>Vibration</i>	5.9m/s 2 (0.6G) or less.

4 Mechanical Installation

4.1 Handling

CAUTION

Hold and lift the inverter by the chassis/heatsink, **not** by the cover. The cover is a protective shield only, and is not intended for lifting and carrying. Lifting the inverter by the cover or other front parts may result in damage.

4.2 Environment

- The inverter should be installed in an adequately-ventilated, steel enclosure.
- The inverter is designed to operate at full rating at an altitude not above 1000m (3280 ft). Derate if installed above this.

Install the inverter in a location that meets the following requirements:

- Ambient temperature between -10°C and $+50^{\circ}\text{C}$ ($+14^{\circ}\text{F}$ to $+122^{\circ}\text{F}$).
- If the ambient maximum temperature exceeds 40°C (104°F), **remove the ventilation covers** located one on either side to allow increased air flow.

For other operating environment specifications, refer to Section 3.4, page 5.

4.3 Position and Materials

- Position the inverter vertically so that the inscriptions on the keypad panel are the right way up.
- Bolt the inverter firmly to a rigid structure.
- The material of the mounting panel should be able to tolerate the temperature attainable by the inverter heatsink, normally 90°C (194°F).
- The fixing bolts should be used with nuts or washers that will resist vibration.
- **Do not overtighten the fixing bolts.**

4.4 Cooling and Ventilation

For inverter heat losses refer to page 64.

Observe the minimum clearances shown in the illustration below.

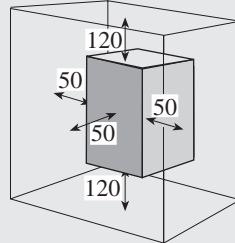

Minimum clearances (mm) from the inverter to any other equipment.

The inverter should be installed in an enclosure. The minimum clearances to adjacent equipment must be allowed.

If two or more inverters are to be installed in

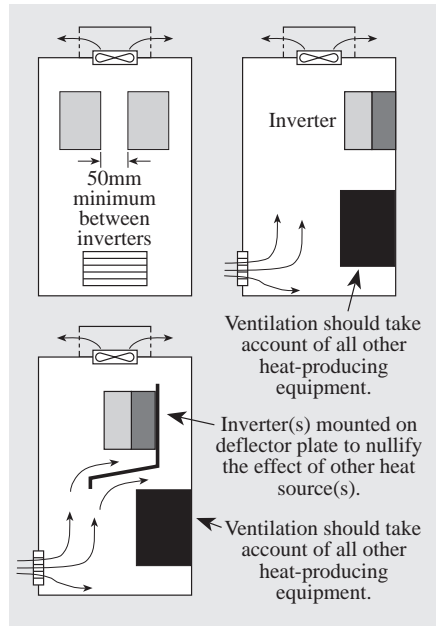

the same enclosure, they should ideally be side by side at a minimum spacing of 50mm. If an inverter is to be mounted above heat-producing equipment of any type, precautions must be taken to ensure that the heat generated by the lower unit does not affect the upper. A deflector plate may be fitted below the inverter to nullify the heating effect, as illustrated on the previous page.

4.5 Removable Covers and Keypad

Front cover

It is not necessary to remove the inverter front cover for cooling. It should be left in place, except when wiring up, for safety.

Removable side covers

Removable covers are fitted to the sides of the inverter. Normally these should be left in

place. If the ambient temperature of the installation is likely to exceed 40°C, these covers should be removed.

The temperature within an enclosure should not exceed 50°C under any circumstances.

Removable keypad

The keypad can be detached from the front cover and mounted remotely (max. distance 5m).

Two keypad retaining screws can be released from the back when the front cover is removed.

A 2m screened connector cable with fitted terminations is available.

4.6 Dimensions

VXS20-1 (Single Phase)

Dimensions in mm

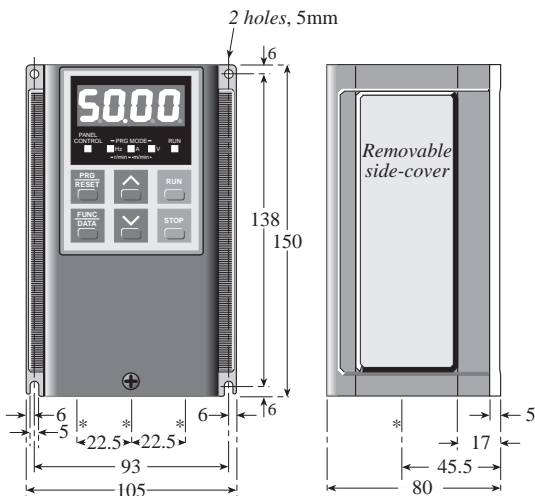

*Centrelines of 3 cable entry holes, 18mm dia.

4.6 Dimensions *continued*

VXS40-1 and VXS75-1 (Single Phase) VXS40-3 and VXS75-3 (Three Phase)

Dimensions in mm

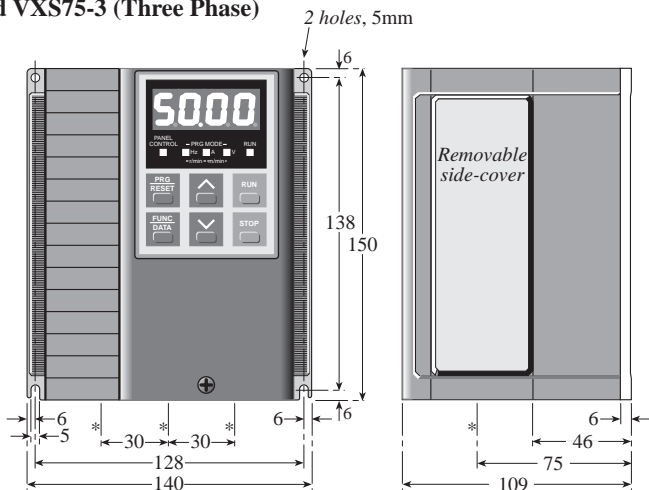

**Centrelines of 3 cable entry holes, 22mm dia.*

VXS150-1 and VXS220-1 (Single Phase) VXS150-3 and VXS220-3 (Three Phase)

Dimensions in mm

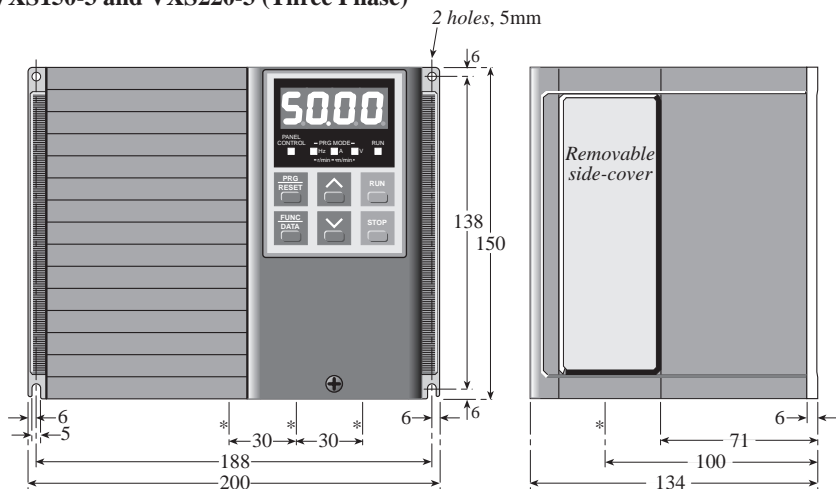

**Centrelines of 3 cable entry holes, 22mm dia.*

4.6 Dimensions *continued*

VXS400-3 (Three Phase)

Dimensions in mm

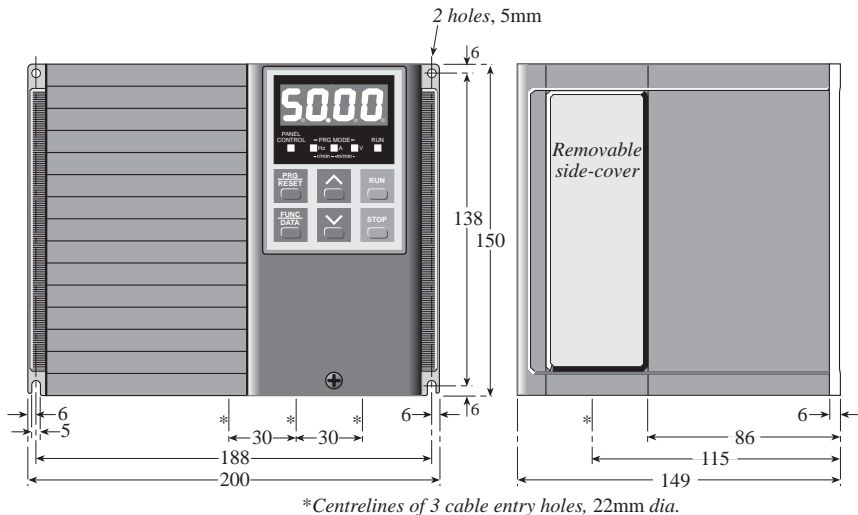

Keypad and Drilling Pattern for Remote Mounting

Dimensions in mm

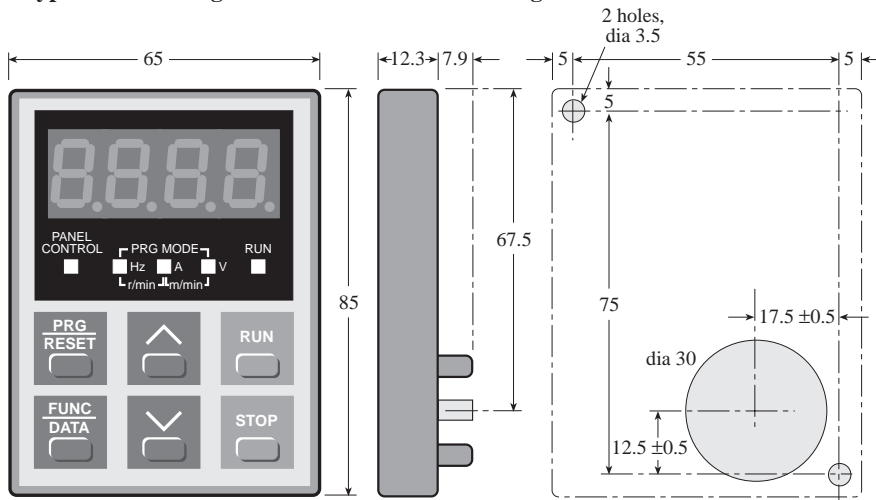

5 Electrical Installation

WARNING

ELECTRICAL SHOCK HAZARD

Do not touch any electrical parts of the inverter when the power supply is connected, even if the inverter output is at STOP. After the power supply has been disconnected, the built-in smoothing capacitor will hold a residual charge. It takes up to 10 minutes for the capacitor to discharge completely. To avoid danger, wait until the charge indicator LED is extinguished.

WARNING — SAFETY EARTHING

The inverter chassis, motor base and equipment enclosure structure should be earthed in accordance with the national and local safety specifications in force.

CAUTION

Do not connect any supply voltage that exceeds the standard voltages and variations specified on page 3, or the inverter will be damaged and the Warranty will be invalidated.

5.1 Power Connection Block Diagrams

These diagrams are not suitable for Electromagnetic Compatibility (EMC), refer to page 58.

For the Table of Cable Sizes and Maximum Lengths, refer to page 63.

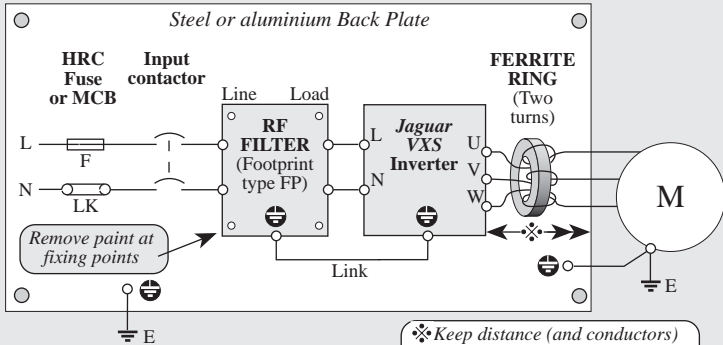

240V 50/60Hz Single-phase

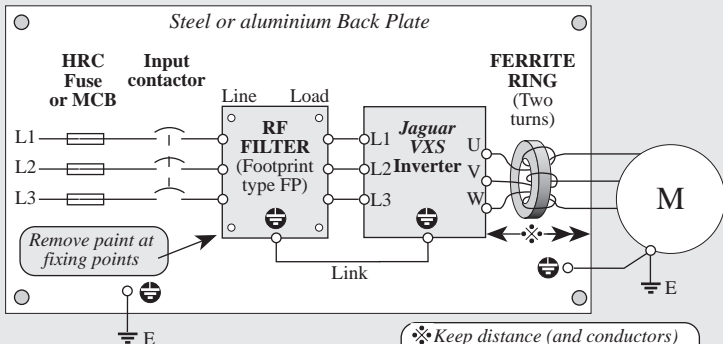

415V 50/60Hz Three-phase

CAUTION

Do not overtighten terminal screws.

5.2 Power Circuits

Access to Terminals

Remove the front cover by releasing the single captive screw near the lower edge of the cover. Press firmly inwards on the sides of the cover near the lower edge and lift it away.

Power terminals and control terminals are now accessible from the front.

Power Input/Output Terminal Blocks

Single phase inverter VXS20-1

—	L	N	PI	(+)	—	U	V	W
---	---	---	----	-----	---	---	---	---



Single phase inverters VXS40-1 to 220-1

—	L	N	PI	(+)	DB	U	V	W
---	---	---	----	-----	----	---	---	---



Three phase inverters, all sizes

L1	L2	L3	PI	(+)	DB	U	V	W
----	----	----	----	-----	----	---	---	---



CAUTION

Connect the power supply to the power terminals L, N (1-phase) or L1, L2, L3 (3-phase), NOT to the output terminals U, V, W, or to the control terminals.

Power Input Circuit

It is essential that the incoming supply circuit to the inverter is properly protected against short-circuit and earth faults.

The alternatives are a suitably-rated fused contactor, MCB or RCD to ensure that the line and neutral (or all three phases) are operated simultaneously.

For ratings refer to pages 3 or 63.

Power Output Circuit

CAUTION

Motor thermal overload protection is desirable. Use either the inverter electronic overload protection, or a motor thermistor and thermistor relay.

CAUTION

Do not install filter capacitors, power factor correction capacitors, a surge absorber or any form of automatic switchgear on the output side of the inverter.

Connect a three-phase squirrel-cage motor to the output terminals U, V, W in the correct sequence, preferably using screened or armoured cable. If the operational commands FWD and REV do not match the desired direction of motor rotation, interchange any two of the U, V, W connections. It is not necessary to change the power input connections.

The motor circuit is protected by the inverter software against overload provided that Functions 15 & 16 (and Functions 66 & 67 if applicable) are correctly set. The inverter automatically protects the power output circuit against short circuit and earth faults.

The installation of any type of automatic or semi-automatic switchgear in the inverter output circuit is **not recommended** (see below) except for changeover switching when two motors are supplied from the one inverter.

Power Output Circuit Isolation

An isolator may be installed in the inverter output circuit for reasons of operational safety. Auxiliary contacts (early break, late make), should interface with the inverter control terminals. **On no account should the isolator be used to control the start/stop operation of the motor.** Consult IMO Precision Controls Ltd if in any doubt.

5.3 Control Circuits

DC Bus Reactor

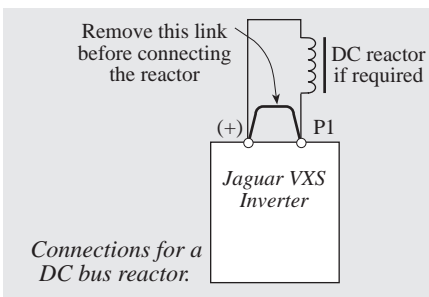

NOTE If a reactor is not fitted to the inverter, it is **essential** that terminals (+) and P1 remain linked.

IMO Precision Controls Ltd recommend the use of a DC reactor to improve the overall power factor and to reduce the harmonics reflected into the supply network.

Braking Terminals

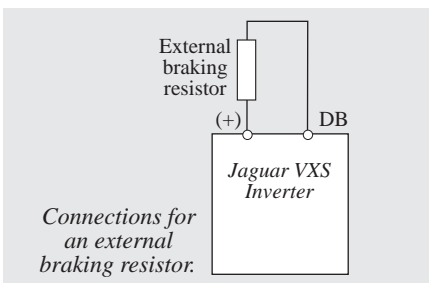

Jaguar VXS inverters (except VXS20-1) are equipped with an internal resistor to apply dynamic braking as standard. If additional braking torque is required, an external braking resistor can be connected to terminals (+) and DB.

A thermal overload sensor for the resistor is essential to protect the inverter. The thermal protection should be arranged to trip the main power supply switch and/or terminal THR, page 15. For further information, refer to Chapter 9.

WARNING

The STOP pushbutton on the keypad is effective **ONLY** when Function 02 = 0. If Function 02 is set to 1, an external RUN/STOP control circuit may be required at terminals FWD or REV for safety. The factory-fitted link, shown below, should be replaced by an external control contact.

WARNING

The RUN and STOP inputs, whether at the keypad or terminals FWD or REV, should not be relied upon to ensure the safety of personnel. If a safety hazard could arise from the unexpected starting of the motor, an interlock mechanism should be provided to prevent the motor from starting except when it is safe for it to do so.

FWD/REV Input Terminals

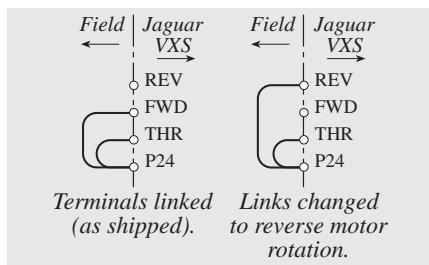

At the time of shipment, terminals FWD-P24 are connected by a solid link and Function 02 is set to the default value 0. This puts the inverter in keypad operating mode, in which the inverter is operated by the RUN and STOP keys.

NOTE Whilst terminal FWD or REV is connected to terminal P24, Function 02 cannot be changed.

To reverse the direction of motor rotation in keypad mode, link terminal P24 to REV instead of FWD as shown in the diagram above.

Control Terminal Block — all models

30A	30B	Y1E	FMA	BX	RST	C1	13	12	11	CM	CM
30C	CMC	FMP	X1	X2	X3	X4	REV	FWD	THR	P24	P24

Control Circuits

Use 0.75mm² wiring. All control circuits should be screened as shown in the illustration in the adjacent column.

NOTE If control signals originate from a process controller, it is recommended that the screening should be terminated at the source end rather than at the inverter end as shown in all illustrations in this manual.

Control wiring should be installed at least 300mm distant from any power system cables, and if the two types of conductors must cross they should be arranged as nearly as possible at right angles to each other.

The function of each control terminal is given in the table on the following page.

Control Input Circuits

Contactors or switch contacts should be carefully selected for high reliability and absence of closing defects.

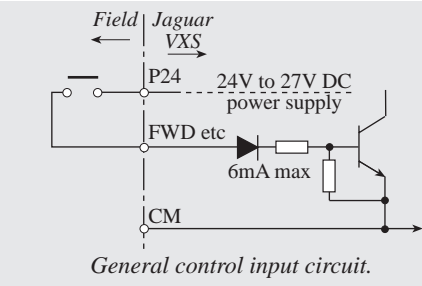

Control Output Circuit

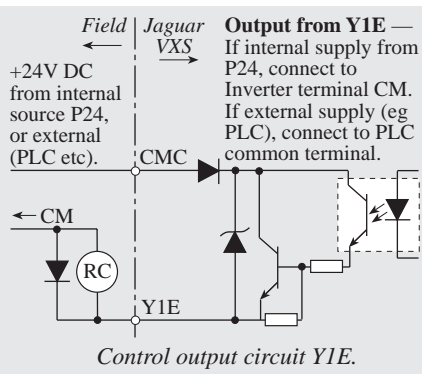

Screening of Control Circuits

Control screening should be connected to a 0V common terminal at the inverter end only, as shown below. If an external process controller or PLC is used, it is recommended that the screening should be connected at the end remote from the inverter.

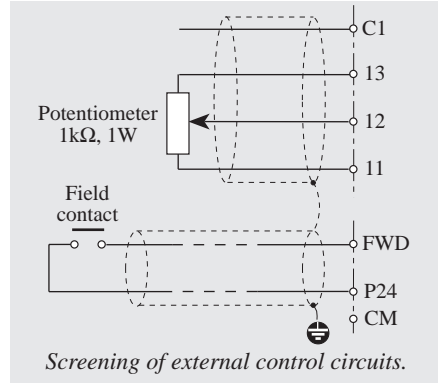

Suppression of Control Circuits

Sudden changes of flux in the operating coils of relays and magnetic contactors induce high transient EMFs which may cause 'noise' on the control circuits, resulting in possible malfunction of internal or external circuits. It is advisable to suppress these coils in the manner shown below.

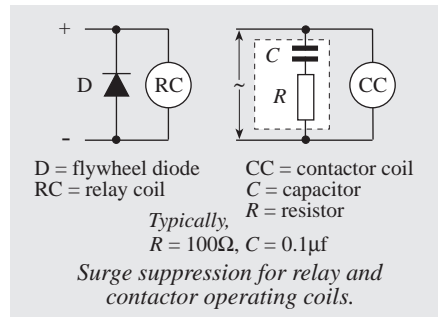

5.4 Terminals Functions List

Terminal	Terminal Function	Description
----------	-------------------	-------------

Power Circuits

L, N	Power supply input to inverter	Single phase AC power supply.
L1, L2, L3	Power supply input to inverter	Three phase AC power supply.
U, V, W	Power output to 3-phase motor	
(+), P1	DC reactor	Optional. Improves p.f. and reduces harmonics.
(+), DB	External dynamic braking resistor	Optional (DB not available for VXS20-1).
	Earth terminal	WARNING! Inverter must be earthed.

Frequency Input Reference

11	Common 0V	For terminals 12, 13, C1 and FMA.
12	Reference input voltage	0 to +10V DC = 0Hz to max. freq. $Z = 22k\Omega$.
13	Pot. (1k Ω , 1W) power supply	+10V DC power supply; max output 10mA.
C1	Reference input current	4 to 20mA DC = 0Hz to max. freq. $Z = 250\Omega$.

Control Inputs

FWD	RUN/STOP command — forward	-P24 closed = RUN forward; open = decel. & stop.
REV	RUN/STOP command — reverse	-P24 closed = RUN reverse; open = decel. & stop.
BX	Coast-to-stop command	-P24 closed = coast to stop.
THR	External fault/alarm trip command	-P24 open = OH2 trip and coast.
RST	Reset inverter after protective trip	-P24 closed momentarily (>0.1s) = reset.
X1, X2	'Motorised pot.'	X1-P24 closed = accel. time 1 (Function 06). X2-P24 open = decel. time 1 (Function 07).
X1, X2, X3	Preset frequency select	Terminals enable 7 different frequencies to be preset.
X4	Auxiliary control input Four functions according to data set in Function 43: When F43 = 0, X4-P24 closed selects accel/decel time 2 (Functions 63 and 64). When F43 = 1, X4 functions as a fourth signal, allowing 15 preset frequencies. When F43 = 2, X4-P24 closed selects base frequency 2 (Function 62). When F43 = 3, X4 functions as a 'hold' (HLD) signal for 3-wire operation.	
P24	Control power supply (two) CAUTION Do not short circuit to either terminal 11 or CM .	Internal 24V DC supply. Capacity is adequate to support all input control circuits plus Y1E output <i>provided that</i> the load at Y1E is not >50mA.
CM*	Common terminals (two)	Common for FMP, Y1E and external control contacts.

Monitor Outputs

FMA	Analog monitor	0 to 10V DC 1mA max. output, proportional to the value of four parameters (refer to Functions 09, 40 and 41): Output frequency; output current; calculated torque %; load factor %.
FMP	Output frequency monitor (pulse)	O/P pulse rate = O/P frequency x Function 42. O/P voltage = 15V peak-to-peak.

* The two terminals CM are at the same potential as terminal 11.

5.4 Terminals Functions List *continued*

Terminal	Terminal Function	Description
Control Outputs		
Y1E	Open emitter output; 50mA max.	Six different functions are available according to preset selection; refer to Function 54.
CMC	Reserved for Y1E output only	Refer to the illustration on page 13.
30A, 30B, 30C	Alarm output, all trips	When no trip, N/O circuit 30A-30C; N/C circuit 30B-30C. When inverter trips, 30A-30C closes. Rating 48V DC, 0.3A.

5.5 Control Circuits and Terminals

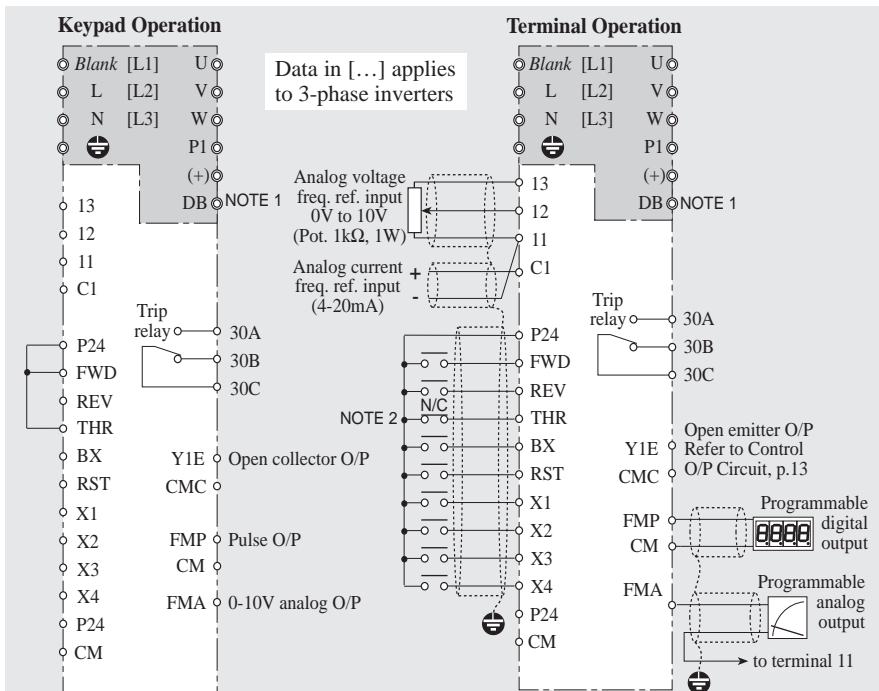

NOTES

- Terminal DB not available for VXS20-1.
- Input to terminal THR, (N/C contact) from external protection relay.

TRIP/ALARM RELAY

Relay is shown with the inverter in either the power-off or power-on state, condition 'healthy'.

CAUTION

Do not short-circuit terminal P24 to either 11 or CM. Damage may result.

6 Keypad Functions

6.1 Keypad



At Power-on

When power is switched on, the 7-segment LEDs display flashes together with the (red) 'Hz' LED below it if the inverter is in the as-delivered condition, and the (green) Panel Control LED also illuminates, not flashing.

The 7-segment LEDs display normally shows the value set in Function 03 (max. output frequency). The frequency output can be changed to current, voltage, speed (rpm) or line speed (m/min). Refer to 'Changing the Inverter Output Display' in the next column.

When one of these has been selected and the inverter switched off, that same output will appear at the next power-on.

Keypad Mode

The inverter is factory-set in Keypad Mode (Functions 01 = 0 and 02 = 0) and is locked into that mode by the standard link applied to terminal P24-FWD. **If it is desired to operate the inverter in Terminal Mode, this link must first be removed before either Function 01 or Function 02 can be changed.**

Functions 01 and 02 can be changed independently of each other.

6.2 Keypad Procedures

Changing the Inverter Output Display

- Illuminated in RUN mode
Flashing in STOP mode

Illuminated (not flashing) in RUN mode

PANEL CONTROL PRG MODE Hz A V RUN
r/min m/min

PRESS **FUNC DATA**

Motor current

PANEL CONTROL PRG MODE Hz A V RUN
r/min m/min

PRESS **FUNC DATA**

Output voltage

PANEL CONTROL PRG MODE Hz A V RUN
r/min m/min

PRESS **FUNC DATA**

Motor speed

PANEL CONTROL PRG MODE Hz A V RUN
r/min m/min

PRESS **FUNC DATA**

Line speed

PANEL CONTROL PRG MODE Hz A V RUN
r/min m/min

PRESS **FUNC DATA**

WARNING

The STOP pushbutton on the keypad is effective ONLY when Function 02 = 0. If Function 02 is set to 1, an external RUN/STOP control circuit may be required at terminals FWD and REV for safety.

WARNING

If a RESET is performed while a RUN command is present, the inverter **will start**. To avoid danger, check that a RUN signal is not present before performing a RESET.

STOP Mode Display

7-segment LEDs display flashing. Three output data LEDs flashing.

The 7-segment LEDs display normally shows the maximum output frequency data set in Function 03 or whichever other inverter output value has been selected for display (refer to Changing the Inverter Output Display, page 16).

When a keypad or a terminal STOP command is given, the following will be observed:

The RUN (green) LED is extinguished;

The motor decelerates;

The 7-segment LEDs display shows the decreasing speed (or other output, as selected);

When the output stops, the LEDs flash;

The 7-segment LEDs display shows whichever output value has been selected.

RUN Mode Display

7-segment LEDs display and three output data LEDs are illuminated, not flashing.

The 7-segment LEDs display normally shows the actual output frequency, or whichever other inverter output value has been selected for display (refer to Changing the Inverter Output Display, page 16).

When a keypad or a terminal RUN command is given, the following will be observed:

The LEDs stop flashing, become steady;

The RUN (green) LED illuminates;

The motor accelerates;

The 7-segment LEDs display shows the increasing frequency (or other output, as selected).

RUN/STOP keys

- *Keypad Mode (Function 02 = 0)*
‘Panel Control’ LED ON

Start and stop commands. Inverter will accelerate and decelerate in the time set in Functions 06 and 07. It will decelerate when the STOP key is pressed whether it has reached full speed or not, and re-accelerate when the RUN key is pressed, whether it has reached zero speed or not.

- *Terminal Mode (Function 02 = 1)*
‘Panel Control’ LED OFF

No effect. Use terminals FWD/REV-P24.

UP and DOWN keys (^ and v)

- *Keypad Mode (Function 01 = 0)*

Change the maximum output frequency data value set in Function 03.

- *Terminal Mode (Function 01 = 1)*

No effect. Use terminals 12/C1-11.

- *Programming Mode*

Refer to the following page.

RUN/STOP terminals FWD/REV-P24

- *Keypad Mode (Function 02 = 0)*
‘Panel Control’ LED ON

Terminal control is disabled.

- *Terminal Mode (Function 02 = 1)*
‘Panel Control’ LED OFF

RUN Mode

Close the external contact in the control circuit connecting P24-FWD or P24-REV.

STOP Mode

Open the external contact in the control circuit connecting P24-FWD or P24-REV. Refer also to Function 43 = 3.

INPUT REFERENCE terminals 12-11 and/or C1-11

- *Keypad Mode (Function 01 = 0)*

Terminal control is disabled.

- *Terminal Mode (Function 01 = 1)*

Analog frequency control inputs. If both inputs 12-11 and C1-11 are used, the resulting reference is the sum of the two.

PRG/RESET key

- *RUN mode or STOP mode*

In either keypad mode or terminal mode, and provided that the inverter is not in a TRIP condition, the PRG/RESET key sets the inverter into PROGRAM mode, allowing the operator to select the menu of Inverter Functions (Chapter 7).

When PRG mode is selected, the LED display shows the Function available, *eg* F 00, and all three red LEDs below it illuminate in RUN mode or flash in STOP mode.

For the explanation of procedures and the use of the ^ and v keys, refer to the diagrams on the following pages.

- *TRIP Mode*

In TRIP mode, the PRG/RESET key resets the inverter. Refer to Chapter 8.

FUNC/DATA key

- *RUN mode or STOP mode*

The Function/Data key calls up the Data of the Function selected in PROGRAM mode.

For the explanation of procedures and the use of the ^ and v keys, refer to the diagrams on the following pages.

- *STOP Mode*

The FUNC/DATA key permits the selection of one of the 5 different inverter output parameters for display on the 7-segment LEDs.

Refer to Changing the Inverter Output Display, page 16.

NOTES

- 1 All Functions can be read in both RUN and STOP modes, and all Functions can be adjusted in STOP mode. In RUN mode, some Functions are 'read only'. Refer to Chapter 7.
- 2 If Function Data is protected, adjustment is not possible. Refer to Function 00 page 26, and Function 57 page 37.

To SELECT a Function

- Illuminated in RUN mode
Flashing in STOP mode



Flashing in
STOP mode

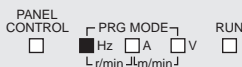

PRESS

**PRG
RESET**

To exit and return to
operating-function
data screen any time.

PRESS

**PRG
RESET**

To SELECT the
next Function

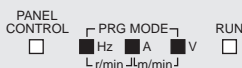

Three LEDs (red)
Illuminated in RUN mode
Flashing in STOP mode

Either —
PRESS



...to move to
next Function

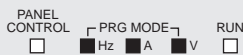

Or —
PRESS
and HOLD



to scroll forwards.
At F 79, the sequence
continues from F 00.

Or —
PRESS
and HOLD



to scroll backwards.
At F 00, the sequence
continues from F 79.

To READ Function data

Example —

Function selected...



PRESS

**FUNC
DATA**



present data value

PRESS

**FUNC
DATA**

to ACCEPT without change and step to next Function.

PRESS

**PRG
RESET**

to exit and return to operating-function data screen any time.

To ADJUST Function data

Example — Function selected...



PRESS



Present data value...



then

Either —

PRESS



Or —

PRESS



PRESS



To STORE the data and go to the next Function.

OR



To CANCEL a change, RESTORE the previous data, and return to RUN or STOP mode.

NOTE All Functions can be adjusted in STOP mode. In RUN mode, some Functions are 'read only'. Refer to Chapter 7.

To RESTORE Function Data to Default

Select...



PRESS



Present data value...



PRESS



and



together

New data value...



Then EITHER...

PRESS



To RESTORE the data to factory-set defaults.

NOTE All custom data will be lost.

OR — to cancel F39 = 1...

PRESS



and



together

Data value changed back to...



PRESS



To resume custom settings

NOTE If Function Data is protected, neither of the procedures shown on this page is possible. Refer to Function 00 page 26, and Function 57 page 37.

7 Inverter Functions

7.1 Functions Data

<i>Function</i>		<i>Setting Range</i>	<i>Unit</i>	<i>Resol.</i>	<i>Def.</i>
<i>No.</i>	<i>Name</i>				
00	Data protection (See also Function 57)	0 = No protection 1 = Data protected (read only)	—	—	0
01	Input frequency reference — <i>mode</i>	0 = Keypad mode, \wedge and \vee keys 1 = Terminal mode, I2/C1-11 2 = Motorised pot. refer to diagrams, p.26 3 = Motorised pot.	—	—	0
02	Control mode	0 = Keypad mode, RUN, STOP 1 = Terminal mode, P24-FWD/REV	—	—	0
03	Max. output frequency	50 to 400	Hz	1	50
04	Base frequency 1 (for Base freq. 2 see F62)	(Motor 1) 15 to 400	Hz	1	60
05	Max. output voltage	0 = $V \propto f$ ($V \leq V_L$ max.) 0, 80 to 240 [0, 160 to 480] — selectable V 'shelving'	V	1 [2]	230 [400]
06	Acceleration time 1	0 to 3600	s	0.01	6.00
07	Deceleration time 1	0 to 3600	s	0.1	6.00
	(for Acc./Dec. 2 see F63/64)	100 to 999 1000 to 3600		1 10	
08	Torque boost 1 (for Torque boost 2 see F65)	0 = Automatic torque boost 1 = Squared characteristic (for pumps and fans) 2 = Proportional characteristic 3 = Low linear boost... ...increasing in unit steps to... 31 = High linear boost	—	1	0
09	FMA voltage	0 = 6.5V approx. ...increasing in units steps to... 99 = 10.5V approx.	—	1	85
10	Motor poles	2 = 2-pole ...increasing in steps of 2 to... 12 = 12-pole <i>Example:</i> When a 4-pole motor is running at 50Hz, display will read: $120 \times 50 \div 4 = 1500\text{rpm}$	—	2	4
11	Line speed coefficient	0 to 200 0.01 to 9.99 10.0 to 200.0 <i>Example:</i> Display value in m/min = O/P freq. (Hz) x coefficient	—	0.01 0.1	0.01
12	PWM carrier frequency	0 = 0.75kHz 1 = 1kHz, to 15 = 15.6kHz	kHz	1	5

Functions in can be adjusted while the inverter is running. Data in [...] applies to three phase inverters.
Resol. = resolution; Def. = Factory-set defaults — refer to Function 39.

<i>Function</i>		<i>Setting Range</i>		<i>Unit</i>	<i>Resol.</i>	<i>Def.</i>
<i>No.</i>	<i>Name</i>					
13	Restart attempts	0 to 10		—	1	0
14	Restart mode	0 = Inactive; no restart LU indication on V loss 1 = Inactive; no restart LU indication on I/P voltage recovery 2 = Active; restart at same O/P frequency as when trip occurred. 3 = Active; restart at 0Hz		—	—	0
15	Electronic thermal overload 1 — <i>mode</i> <i>(for Electronic thermal o/1 2 see F66/67)</i>	(Motor 1) 0 = Inactive 1 or 3 = Active (standard 4-pole motors) 2 or 4 = Active (inverter-rated motors)		—	—	2
16	Electronic thermal overload 1 — <i>level</i>	(Motor 1) 0.01 to 99.9	0.01 to 9.99 10.0 to 99.9	A	0.01 0.1	*
		* <i>Default factory-set at rated current for a 4-pole standard motor for each inverter frame size.</i>				
17	DC injection braking — <i>mode</i>	0 = Inactive 1 = Active		—	—	0
18	DC injection braking — <i>starting frequency</i>	0 to 60 NOTE 0 = 0.2Hz		Hz	1	0
19	DC injection braking — <i>level</i>	0 to 100 Percent of inverter rated current		%	1	50
20	DC injection braking — <i>time</i>	0 to 30	0.00 to 9.99 10.0 to 30	s	0.01 0.1	0.5
21	Preset speed 1	0 to 400	0.00 to 99.99 100 to 400	Hz	0.01 0.1	0.00
22	Preset speed 2	0 to 400	0.00 to 99.99 100 to 400	Hz	0.01 0.1	0.00
23	Preset speed 3	0 to 400	0.00 to 99.99 100 to 400	Hz	0.01 0.1	0.00
24	Preset speed 4	0 to 400	0.00 to 99.99 100 to 400	Hz	0.01 0.1	0.00
25	Preset speed 5	0 to 400	0.00 to 99.99 100 to 400	Hz	0.01 0.1	0.00
26	Preset speed 6	0 to 400	0.00 to 99.99 100 to 400	Hz	0.01 0.1	0.00
27	Preset speed 7	0 to 400	0.00 to 99.99 100 to 400	Hz	0.01 0.1	0.00
28	S-ramp accel./decel. — <i>selector</i>	0 = Inactive; linear accel. and decel. 1 = Active; quick S-ramp 2 = Active; slow S-ramp		—	—	0

Functions in can be adjusted while the inverter is running. Data in [...] applies to three phase inverters.
Resol. = resolution; *Def.* = Factory-set default — refer to Function 39.

<i>Function</i>		<i>Setting Range</i>	<i>Unit</i>	<i>Resol.</i>	<i>Def.</i>	
<i>No.</i>	<i>Name</i>					
29	Protection history	Last 4 protection trips, last trip first	—	—	—	
30	Starting frequency	0 to 15 NOTE 0 = 0.2Hz	Hz	1	1	
31	Torque limit — <i>accel./decel.</i>	0 = No limit 20 to 180 = Limit active	%	1	0	
32	Torque limit — <i>constant speed</i>	0 = No limit 20 to 180 = Limit active	%	1	0	
33	Braking torque — <i>selector</i>	0 = Low (when no dynamic brake resistor) 1 = High (with dynamic brake resistor)	—	—	0	
34	Bias frequency	-400 to +400	Hz	1	0	
35	Input frequency reference — <i>gain</i>	0 to 250 0.00 to 9.99 10.0 to 250.0	%	0.01 0.1	100.0	
36	Frequency limiter — high	0 to 400	Hz	1	70	
37	Frequency limiter — low	0 to 400	Hz	1	0	
38	O/P current stability	0 to 10	—	1	5	
39	Data initialisation	0 = Hold custom settings 1 = Reinstate factory-set default values	—	—	0	
40	Terminals FMA/FMP — <i>selector</i>	0 = FMA output (analog signal) 1 = FMP output (digital pulse signal)	—	—	0	
41	Terminal FMA — <i>function</i>	0 = Output frequency 1 = Output current 2 = Output torque 3 = Load factor	—	—	0	
42	Terminal FMP — <i>pulse rate multiplier</i>	10 to 100	—	1	24	
43	Terminal X4 — <i>functions</i>	0 = Command I/P for accel./decel. 2 1 = Fourth I/P allowing 15 Preset speeds 2 = Command I/P for base freq. 2 3 = 'Hold' signal (latch for 3-wire I/P)	—	—	0	
44	Preset speed 8	0 to 400 0.00 to 99.99 100 to 400	Hz	0.01 0.1	0.00	
45	Preset speed 9	0 to 400 0.00 to 99.99 100 to 400	Hz	0.01 0.1	0.00	
46	Preset speed 10	0 to 400 0.00 to 99.99 100 to 400	Hz	0.01 0.1	0.00	
47	Preset speed 11	0 to 400 0.00 to 99.99 100 to 400	Hz	0.01 0.1	0.00	
48	Preset speed 12	0 to 400 0.00 to 99.99 100 to 400	Hz	0.01 0.1	0.00	

Preset Speeds 13, 14, 15 overleaf

Functions in can be adjusted while the inverter is running. Data in [...] applies to three phase inverters.
Resol. = resolution; Def. = Factory-set defaults — refer to Function 39.

<i>Function</i>		<i>Setting Range</i>		<i>Unit</i>	<i>Resol.</i>	<i>Def.</i>
<i>No.</i>	<i>Name</i>					
49	Preset speed 13	0 to 400	0.00 to 99.99 100 to 400	Hz	0.01 0.1	0.00
50	Preset speed 14	0 to 400	0.00 to 99.99 100 to 400	Hz	0.01 0.1	0.00
51	Preset speed 15	0 to 400	0.00 to 99.99 100 to 400	Hz	0.01 0.1	0.00
52	Frequency reference filter	0.02 to 5.00		s	0.02	0.06
53	Operation timer	0.00 = Inactive 0.01 to 3600	0.01 to 9.99 10.0 to 99.9 100 to 999 1000 to 3600	— s	— 0.01 0.1 1 10	0.00
54	Terminal Y1E — <i>functions</i>	0 = Inverter running 1 = Freq. level (FDT) detection 2 = 'At Speed' signal (FAR) 3 = Undervoltage trip activated (LU) 4 = Torque limit activated (TL) 5 = Auto-restart after power loss (IP)		—	—	1
55	Frequency detection — <i>FDT level</i>	0 to 400	0.00 to 99.99 100 to 400	Hz	0.01 0.1	50.00
56	Hysteresis bandwidth — <i>for FDT & FAR</i>	0 to 30		Hz	1	10
57	Terminal THR — <i>function</i>	0 = THR external trip function 1 = Data protection lock		—	—	0
58	Skip frequency — <i>hysteresis</i>	0 to 30		Hz	1	3
59	Skip frequency 1	0 to 400		Hz	1	0
60	Skip frequency 2	0 to 400		Hz	1	0
61	Skip frequency 3	0 to 400		Hz	1	0
62	Base frequency 2 (<i>for Base freq. 1 see F04</i>)	(Motor 2) 15 to 400		Hz	1	50
63	Acceleration time 2	0 to 3600	0.00 to 9.99	s	0.01	10.0
64	Deceleration time 2	0 to 3600	10.0 to 99.9 100 to 999 1000 to 3600	s	0.1 1 10	10.0
	(<i>for Acc./Dec. 1 see F06/07</i>)					
65	Torque boost 2 (non-auto) <i>NOTE</i> Only if Function 43 = 2 (<i>for Torque boost 1 see F08</i>)	1 = Squared characteristic (for pumps and fans) 2 = Proportional characteristic 3 = Low linear boost... ...increasing in units steps to... 31 = High linear boost		—	1	13

Functions in can be adjusted while the inverter is running. Data in [...] applies to three phase inverters.
Resol. = resolution; *Def.* = Factory-set default — refer to Function 39.

<i>Function</i>		<i>Setting Range</i>	<i>Unit</i>	<i>Resol.</i>	<i>Def.</i>	
<i>No.</i>	<i>Name</i>					
66	Electronic thermal overload 2 — <i>mode</i> <i>(for Electronic thermal o/l 1 see F15/16)</i>	(Motor 2) 0 = Inactive 1 or 3 = Active (standard 4-pole motors) 2 or 4 = Active (inverter-rated motors)	—	—	0	
67	Electronic thermal overload 2 — <i>level</i>	(Motor 2) 0.01 to 99.9 0.01 to 9.99 10.0 to 99.9 0.01 to 99.9 = 20% to 105% of inverter rated current * <i>Default factory-set at rated current for a 4-pole standard motor for each inverter frame size.</i>	A	0.01 0.1	*	
68	Slip compensation	0 = Inactive 0.1 to 5.0 = Active	Hz	0.1	0.0	
69	Torque vector control	0 = Inactive 1 = Active	—	—	0	
70	Motor 1 capacity (frame size)	0 = One size larger than standard 1 = Standard frame size for the inverter 2 = One size below 3 = Two sizes below	—	—	1	
71	Rated current 1	(Motor 1) 0.01 to 99.9 0.01 to 9.99 10.0 to 99.9	A	0.01 0.1	*	
72	No-load current 1	(Motor 1) 0.01 to 99.9 0.01 to 9.99 10.0 to 99.9	A	0.01 0.1	*	
73	Rated current 2	(Motor 2) 0.01 to 99.9 0.01 to 9.99 10.0 to 99.9	A	0.01 0.1	*	
	<i>* Default factory-set at rated current for a 4-pole standard motor for each inverter frame size.</i>					
74	Automatic tuning	0 = Inactive 1 = Active	—	—	0	
75	Tuning %R value	0.00 to 50.00	%	0.01	*	
76	Tuning %X value	0.00 to 50.00	%	0.01	*	
	<i>* Default factory-set at rated value for a 4-pole standard motor for each inverter frame size.</i>					
77	Torque limiter response — <i>constant speed</i>	000 to 999	—	—	369	
78	Torque limiter response — <i>during accel./decel.</i>	000 to 999	—	—	394	
79	Option selector	0 = No options installed 1 = DI option card 2 = DI/O option card 3 = RS option card	—	—	0	

Please consult IMO Precision Controls Ltd for details of options.

7.2 Descriptions of Functions

XX Function

Title boxes with a **heavy type and border** indicate Functions which can be adjusted while the inverter is in RUN mode. Otherwise, the inverter must be in STOP mode. Data shown in [...] applies to 3-phase inverters.

00 Data protection

When Function 00 = 1, all data becomes 'read-only'. To change Function 00, simultaneously press the STOP key and either \wedge or \vee .

Refer also to Function 57 — special use of terminal THR to protect Function data.

01 Input frequency reference

Jaguar VXS inverters can be controlled entirely at the keypad, or by inputs to control terminals only, or by a combination of keypad inputs and terminal inputs. (Refer to Function 02.)

As delivered from the factory, Function 01 = 0. It cannot be changed while the link at terminals FWD-P24 is in place. If the link has been removed and replaced by an external FWD and/or REV control circuit, the contacts must be of the normally-open type.

When Function 01 = 0, the frequency reference input is provided at the keypad, using the \wedge and \vee keys.

When Function 01 = 1, the \wedge and \vee keys are disabled and the frequency input reference is provided by voltage and/or current input reference signals at terminals I2 and C1. (Refer to pages 14 and 15).

NOTE If both a voltage and a current input reference signal are applied, the input reference is the sum of the two.

Motorised pot. mode

When Function 01 = 2 or 3, the inverter responds to commands at terminals FWD/REV-P24, X1-P24 and X2-P24 as shown in the example diagrams below. When FWD/REV-P24 is OFF (STOP command), the next initial frequency is either zero (F01 = 2) or is the last previous frequency (F01 = 3).

Accel./decel 2 can be applied by X4-P24. Refer to Function 43.

NOTE Output frequency may be further modified by Functions 34 and 35.

RAMPS: Default is Accel./Decel. 1. Accel./Decel. 2 if F43 = 0 and X4-P24 is ON

F01 = 2 * Initial value = 0

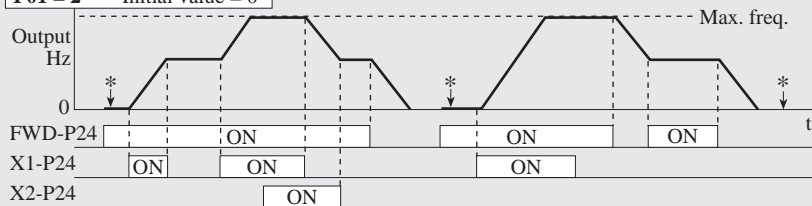

F01 = 3 ** Initial value = Previous value

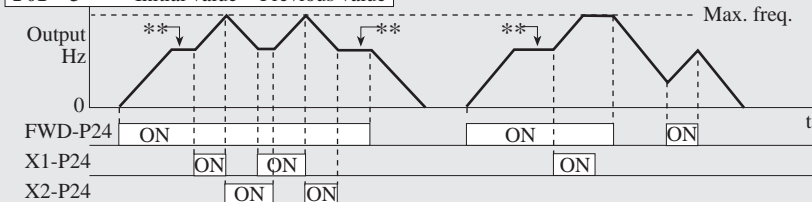

02 Control mode

Jaguar VXS inverters can be controlled entirely at the keypad, or by inputs to control terminals only, or by a combination of keypad inputs and terminal inputs. (Refer also to Function 01.)

As delivered from the factory, Function 02 = 0. It cannot be changed while the link at terminals FWD-P24 is in place. If the link has been removed and replaced by external RUN/STOP control circuits, the contacts must be open.

Keypad control mode

When Function 02 = 0, start/stop commands can be given only by the RUN and STOP keys at the keypad.

When terminals FWD and P24 are linked (as delivered), the inverter will run in a forward direction only. To reverse the motor direction, remove the link from FWD-P24 and link terminals REV-P24 instead.

Terminal control mode

When Function 02 = 1, the RUN and STOP keys are disabled and start/stop commands can be given only at terminals FWD and REV.

03 Maximum output frequency

WARNING *Jaguar VXS* inverters can deliver output frequencies up to 400Hz. It is relatively simple to apply an input reference that would overspeed the motor or driven equipment, and so create danger. Check the capability of the motor and the driven equipment before changing this Function.

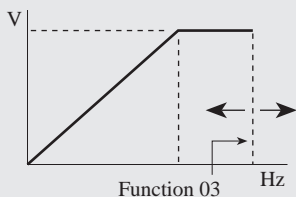

The maximum frequency function limits the inverter output frequency, regardless of input

frequency reference. Maximum frequency can be set from 50Hz to 400Hz in steps of 1Hz.

Frequency output may also be controlled by the Frequency limiter — high, Function 36.

04 Base frequency 1

For Motor 1 only. Refer also to Function 62.

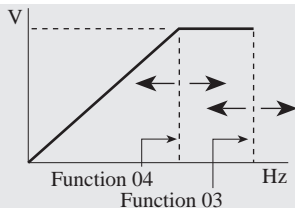

The output voltage and frequency of the inverter are proportional up to base frequency, giving a theoretically constant torque output.

NOTE If base frequency is set higher than maximum frequency (Function 03), the output voltage cannot rise to rated voltage.

05 Rated voltage

The value set in Function 05 is common to both Motor 1 and Motor 2.

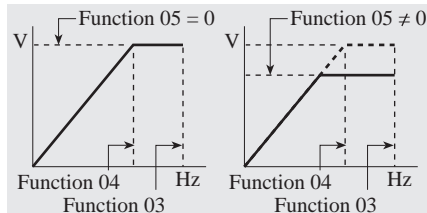

Setting Ranges

0	$V \propto f (V \leq V_L)$
80 to 240	for single-phase inverters
160 to 480	for three-phase inverters

When Function 05 = 0, output voltage is allowed to increase up to actual supply V_L . Inverter output voltage cannot exceed supply voltage V_L .

If Function 05 \neq 0, output voltage will be

'shelved', *ie* limited to the value set in Function 05 regardless of increasing output frequency.

The factory-set default value of Function 05 is 230 [400].

06 Acceleration time 1

07 Deceleration time 1

For Motor 1 only. Refer also to Functions 63 and 64.

Factory-set default values are 6 seconds for both acceleration and deceleration. Accel. time 1 and Decel. time 1 can be set independently in the range from 0.1 (F06/07 = 0.00) to 3600s.

When Function 06 or 07 setting = 0.00, the acceleration or deceleration time is 0.01 sec.

08 Torque boost 1

For Motor 1 only. Refer also to Function 65.

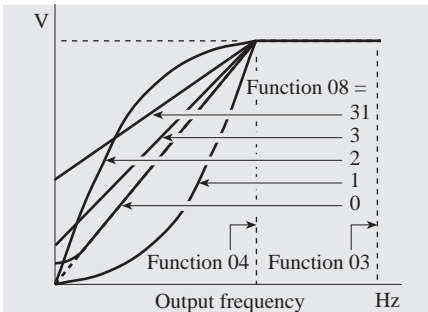

The factory-set default value of Function 08 is 0, giving an automatic increase of voltage output $\propto I_{load}$ at starting speed to overcome the mechanical 'stiction' of a typical installation. (The diagram is not to scale.)

When Function 08 is set to 1, the boost applied is proportional to the square of the speed (frequency) — a suitable characteristic for fans and centrifugal pumps.

When Function 08 is set to 2, the boost is proportional to the torque demand.

Linear boost, inversely proportional to speed, is applied when Function 08 = 3 (low boost) increasing in unit steps to high boost when

Function 08 = 31.

0 = Automatic torque boost

1 = Squared characteristic (for pumps and fans)

2 = Proportional characteristic

3 = Low linear boost...

...increasing in unit steps to...

31 = High linear boost

09 FMA voltage (analog monitor)

Adjusts the DC analog maximum voltage output at terminal FMA in the range from approx. 6.5V to approx. 10.5V so that the full scale of the analog instrument can be used.

The setting range is 0 (= 6.5V approx.) to 99 (= 10.5V approx.), giving very fine adjustment.

NOTE Function 09 is active only when Function 40 = 0. Refer also to Function 41.

10 Motor poles

Adjusts the inverter for the pole-number of the applied motor so that the LED display shows the correct motor field speed in rpm.

The adjustment range is from 2 to 12 poles in steps of 2 poles. Factory-set default is for 4-pole motors.

Example: If a 4-pole motor is running at 50Hz the LED display will show

$$120 \times 50\text{Hz} \div 4\text{poles} = 1500\text{rpm}$$

11 Line speed coefficient

The 7-segment LEDs display can be set to display 'line speed' *ie* the related speed of the driven machine, if required (refer to page 16). Function 11 permits a coefficient or factor to be applied to the inverter output frequency to convert the display value to an equivalent in metres per minute.

Setting ranges

from 0.01 to 9.99 in steps of 0.01

from 10.0 to 200.0 in steps of 0.1

Example:

$$(\text{Function 11}) \times (\text{O/P Hz}) = \text{Display m/min}$$

12 PWM carrier frequency

The PWM carrier frequency is adjustable from 0.75kHz to 15.6kHz.

Setting Ranges

0 = 0.75kHz
and 1 = 1kHz
...in unit steps to...
15 = 15.6kHz

The higher the PWM frequency, the more closely the output current wave approximates to a pure sine wave. Audible noise at the motor is lower at the higher PWM frequencies, but care should be taken to allow for higher losses within the inverter and increased RF emissions from the motor cables.

Refer also to Chapter 10.

13 Restart attempts

WARNING Automatic restarting may be a hazard to personnel working in the vicinity of the motor or the driven machine. It is recommended that appropriate notices are displayed to prevent danger.

Function 13 controls the number of times the inverter will automatically attempt to restart after a trip caused by overcurrent or overvoltage, not by any other cause.

The maximum number of attempts is 10.

Factory-set default value is 0 — no restart.

14 Restart mode

WARNING If Function 14 is set to the value 2 or 3, the inverter **will restart immediately** when power is restored.

There are four modes of Function 14:

- 0 **Inactive.** The motor does **not** restart. The LED display will indicate an LU (undervoltage trip) when the voltage falls below the trip level. This is the factory-set default.
- 1 **Inactive.** The motor does **not** restart. The LED display will indicate an LU

(undervoltage trip) when the voltage is restored.

- 2 **Active.** The motor restarts at the same output frequency as when the trip occurred.
- 3 **Active.** The motor restarts at starting frequency, Function 30.

15 Thermal overload 1 — mode

For Motor 1 only. Refer also to Function 66.

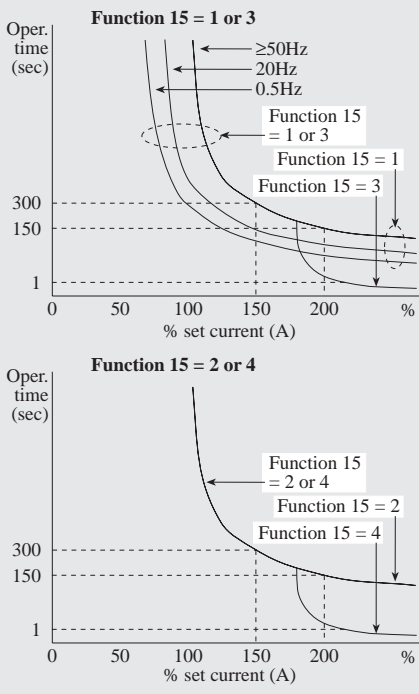

There are five modes of the Function 15:

0 **Inactive.**

1 or 3 **Active.** The factory-set default — suitable for 'standard' 4-pole induction motors.

2 or 4 **Active.** For inverter-rated motors.

Characteristic curves for the settings of Function 15 = 1, 2, 3, 4 are shown above.

16 Thermal overload 1 — level

For Motor 1 only. Refer also to Function 67.

Factory-set default level is at 105% of the current rating of a standard 4-pole induction motor appropriate to the capacity of the inverter. If it is intended to use the inverter to drive a motor of a different frame size, refer to Function 70.

Example 1: For a VXS400-3 4kW inverter driving a 4-pole 2.2kW motor at 415V:

$$\text{Inverter FLC} = 9\text{A}$$

$$\text{Typical 2.2kW motor FLC} = 4.8\text{A}$$

$$\text{Setting for Function 16} = 4.8$$

$$\text{Check: } \frac{\text{Motor FLC}}{\text{Inverter FLC}} = \frac{4.8}{9.0} = 0.533 \text{ or } \underline{53.3\%}$$

which is within the range of 20-105% of **inverter** FLC and the motor is protected.

Example 2: For a VXS400-3 4kW inverter driving a 4-pole 0.37kW motor at 415V:

$$\text{Inverter FLC} = 9\text{A}$$

$$\text{Typical 0.37kW motor FLC} = 1.08\text{A}$$

$$\text{Setting for Function 16} = 1.08$$

$$\text{Check: } \frac{\text{Motor FLC}}{\text{Inverter FLC}} = \frac{1.08}{9.0} = 0.12 \text{ or } \underline{12\%}$$

This is outside the 20-105% range and the motor **is not protected** by the inverter. A stand-alone thermal protection relay should be wired to the motor thermistor. Then set Function 15 = 0 to disable Function 16.

17 Injection braking — mode

WARNING Inverter braking functions are not a substitute for mechanical braking devices designed to ensure safety.

Makes DC injection braking active or inactive.

0 = Braking inactive (factory-set default). This setting may be required for regenerative braking with an external braking resistor.

1 = DC braking active in accordance with the settings of Functions 18, 19 and 20.

18 Injection braking — start freq.

Sets the frequency, in terms of inverter output frequency, at which DC injection braking will be applied. Function 18 = 0 starts braking at 0.2Hz (default). Function 18 = 60 = 60Hz.

19 Injection braking — level

Sets the braking level at a selected percentage of motor rated current in relation to the calculated current in the DC bus. The braking torque will be dependent on the motor characteristics.

0 = No braking current applied

...increasing in steps of 1% to...

100 = 100% of motor equivalent rated current.

The factory-set default value is 50%.

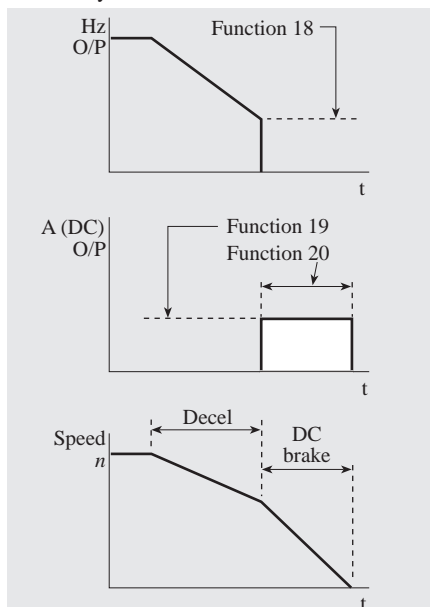

20 Injection braking — time

Sets the time (max. 30s) during which braking will be applied to bring the motor to rest. Note that if the load inertia is high, it is possible that the inverter cannot absorb the rate of energy dissipation if a low time value is set. In such a case, the driven machine may continue to rotate after the braking cycle is complete.

The factory-set default value is 0.5s.

WARNING Inverter braking functions are not a substitute for mechanical braking devices designed to ensure safety.

21 Preset speed 1
22 Preset speed 2
23 Preset speed 3
24 Preset speed 4
25 Preset speed 5
26 Preset speed 6
27 Preset speed 7

Func.	Frequency setting	X1	X2	X3
01	I/P ref. Function 01	<input type="checkbox"/>	<input type="checkbox"/>	<input type="checkbox"/>
21	Preset speed 1	<input checked="" type="checkbox"/>	<input type="checkbox"/>	<input type="checkbox"/>
22	Preset speed 2	<input type="checkbox"/>	<input checked="" type="checkbox"/>	<input type="checkbox"/>
23	Preset speed 3	<input checked="" type="checkbox"/>	<input checked="" type="checkbox"/>	<input type="checkbox"/>
24	Preset speed 4	<input type="checkbox"/>	<input type="checkbox"/>	<input checked="" type="checkbox"/>
25	Preset speed 5	<input checked="" type="checkbox"/>	<input type="checkbox"/>	<input checked="" type="checkbox"/>
26	Preset speed 6	<input type="checkbox"/>	<input checked="" type="checkbox"/>	<input checked="" type="checkbox"/>
27	Preset speed 7	<input checked="" type="checkbox"/>	<input checked="" type="checkbox"/>	<input checked="" type="checkbox"/>

■ = ON □ = OFF

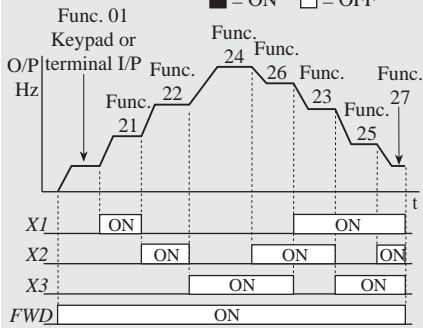

Preset speeds can be used to form an operation pattern of up to eight steps. The desired pattern is activated in the desired sequence by input signals at terminals X1, X2 and X3, as shown in the diagram on page 31.

Each preset speed can be allotted any value from zero to 400Hz:

Setting Ranges

0.00 to 99.99 in steps of 0.01 = 0Hz to 99.99Hz

100.0 to 400.0 in steps of 0.01 = 100Hz to 400Hz

The first frequency step is always the input value of Function 01. This will normally, for

pattern operation, be the input at terminals 12 or C1, although it could be set at the keypad if Function 01 = 0.

All frequencies are subject to any limits imposed by Functions 03, 36 and 37.

The accelerations and decelerations between steps are set by Functions 06 and 07 (Acc./Dec. 1), but may alternatively be set by Functions 63 and 64 (Acc./Dec. 2), if Function 43 = 0. Refer to Function 43, configuration of terminal X4.

28 S-ramp accel./decel. selector

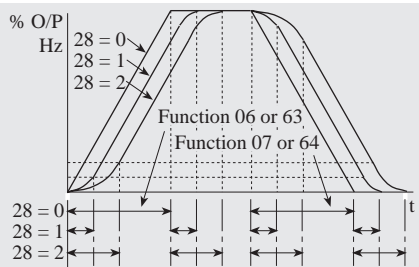

Some applications operate more effectively if abrupt beginnings and ends of accelerations and decelerations are smoothed off to eliminate shocks to loads. *Jaguar VXS* inverters offer linear acceleration and two versions of an S-ramp, as shown in the diagram above.

0 = S-ramp inactive (factory-set default). Acceleration and deceleration are linear.

1 = S-ramp active. Quick transition to or from zero or maximum speed to linear rate of change.

2 = S-ramp active. Slower transition to or from zero or maximum speed to linear rate of change.

The maximum gradient of either S-ramp is the same as that of the linear acceleration/deceleration, Functions 06 and 07 (and 63 or 64)*.

Acceleration and deceleration times set by Functions 06 and 07 (and 63 or 64)* are

* Refer to Function 43, setting = 0

extended by selection of either of the S-ramps:

1 = Accel./decel. time extended by 10% approx.

2 = Accel./decel. time extended by 20% approx.

29 Protection history

Display example
(first select Function 29)

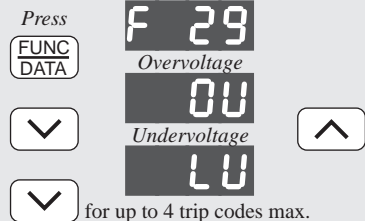

To return to RUN mode press **PRG RESET**

To go to Function 30 press **FUNC DATA**

The inverter holds the trip codes of the last four trips in memory. These are accessed as shown in the diagram above. When a new trip occurs, the previous last (fourth) trip is deleted.

For trip codes refer to page 44.

30 Starting frequency

Starting frequency can be set at any value from 0 up to 15Hz in steps of 1Hz.

NOTE Function 30 = 0 gives 0.2Hz.

Factory-set default is 1.

31 Torque limit during accel./decel.

32 Torque limit at constant speed

Torque limitation is set as a percentage of rated torque computed from Functions 70, 71 and 72.

Setting ranges

0 = No limit (except overcurrent protection)

20 = 20% increasing in steps of 1% to...

180 = 180%

WARNING Accel./decel. times and speed settings may be altered by inappropriate settings of the torque limits. Ensure that the inverter is commissioned with care if torque limits are set.

If in any doubt, consult IMO Precision Controls Ltd.

33 Braking torque selector

The purpose of this Function is to prevent overloading of the braking circuit. Set as follows:

0 = When an external braking circuit is not used or is not available.

1 = Set to this value when installing an external braking circuit.

NOTE External braking is not available with the VXS20-1 inverter.

34 Bias frequency

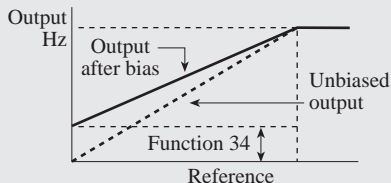

This function adds a positive or negative bias to the frequency reference input, whether the inverter is in keypad mode (Function 01 = 0) or terminal mode (Function 01 = 1). The input reference can be biased from -400Hz to +400Hz (output) in steps of 1Hz.

WARNING If a bias has been set, the motor may rotate when any operating command is given, keypad or terminal—even if the input reference is zero.

35 Frequency reference gain

Function 35 is active only if Function 01 = 1.

Sets the gradient of the change of output frequency corresponding to the analog input frequency reference as a percentage of maximum frequency (Function 03).

The range of the gain setting is from zero to 9.99 in steps of 0.01, and from 10.0 to 250.0 in steps of 0.1 — percent of Function 03.

NOTE If a setting is applied to both Functions 35 and 34 then Function 35, the gain, has priority and the bias, Function 34, is applied to the reference after the gain.

The bias frequency f_{bias} and gain f_{gain} are calculated from the following expressions, where V_1, V_2, f_1, f_2 are as shown in the diagram:

$$f_{\text{bias}} = f_1 - \frac{V_1(f_1 - f_2)}{V_1 - V_2}$$

$$f_{\text{gain}} = \frac{1000(f_1 - f_2)}{100(V_1 - V_2) + (f_1 V_2) - (f_2 V_1)}$$

Function 35 = 70%

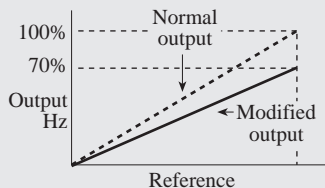

Function 35 = 200%

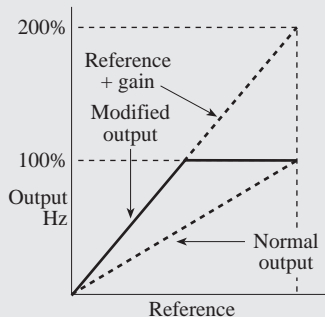

Example:

If the analog frequency reference is 1V to 5V DC and the output frequency is weighted to 0 to 100% then:

$$(V_1, f_1) = (1V, 0\%)$$

$$(V_2, f_2) = (5V, 100\%).$$

Applying these values to the above formulae gives:

$$f_{\text{bias}} = -25\% \text{ and}$$

$$f_{\text{gain}} = 200\%$$

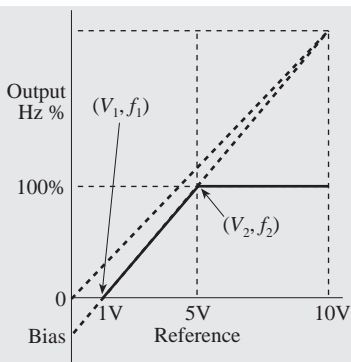

36 Frequency limiter — high

37 Frequency limiter — low

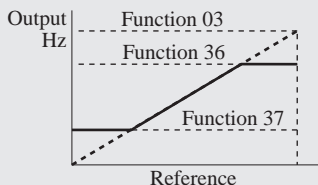

Output frequency can be restricted by setting high and low limits.

If the low limit is set to a value above that of the high limit, the high limit has priority and the low limit is ignored.

If the high limit is set higher than the maximum frequency Function 03, the maximum frequency has priority.

The setting range is 0 to 400Hz in steps of 1Hz.

38 Output current stability

When induction motors are lightly-loaded, instability can occur due to torque pulses corresponding to the 'dead time' of the inverter IGBTs. Output current can be controlled to compensate for this effect by modifying the gain of an internal damping factor. This has the effect of altering the overall motor characteristics computed and recorded by the inverter.

To compensate for instability, set Function 38 lower if the motor has more than 4 poles, higher if the loading is low.

The factory-set default is 5.

Motor characteristic	Poles	
	12	2
Function 38 =	0 ←————→ 10	
Motor load	Load	
	High	Low
Function 38 =	0 ←————→ 10	

39 Data initialisation

Function data settings can be restored to their original factory-set defaults.

To change the setting, select Function 39. The display will show 0. Press the STOP and ^ keys simultaneously; the display will change to 1. The press the FUNC/DATA key to activate the initialisation.

NOTE All custom data will be lost. Refer to page 20.

40 Terminals FMA/FMP selector

An output can be taken from either terminal FMA or terminal FMP, but not both simultaneously.

0 = FMA terminal selected (analog output).
Factory-set default. Refer to Function 41.

1 = FMP terminal selected (digital output).
Refer to Function 42.

Refer also to Function 09.

41 Terminal FMA function

0 = **Inverter output frequency**. Factory-set default.

$$\text{FMA V\%} = \frac{\text{Output frequency}}{\text{Function 03 (max. freq.)}} \times 100$$

1 = **Motor current**

$$\text{FMA I\%} = \frac{\text{Output current}}{\text{Inverter rated current} \times 2} \times 100$$

2 = **Motor torque**

$$\text{FMA M\%} = \frac{\text{Output torque}}{\text{Inverter rated torque} \times 2} \times 100$$

3 = **Load factor**

If output frequency ≤ base frequency:

$$\text{Display 100\%} = \frac{\text{Output torque} \times 100}{\text{Inverter rated torque} \times 2}$$

If output frequency > base frequency:

$$\text{Display 100\%} = \frac{\text{Output (A)} \times 100}{\text{Inverter rated output (A)} \times 2}$$

Refer also to Function 09.

42 Terminal FMP pulse rate

Setting range 10 to 100 in unit steps
Factory-set default = 24

FMP pulse frequency =
Inverter O/P frequency x Function 42.

The multiplier should be chosen so that the output from terminal FMP is not greater than 6kHz.

43 Terminal X4 functions

0 = Terminal X4-P24 acts as a command to select accel./decel. time 2, Functions 63 and 64. Factory-set default.

1 = Terminal X4-P24 acts as a command to extend the available number of preset speeds to 15. Refer to Functions 06, 07, 21 to 27 and 44 to 51.

2 = Terminal X4-P24 acts as a command to select base frequency 2 (Function 62) when using a second motor. When base frequency 2 is selected in this way, accel./decel. time 2 (Functions 63 and 64), torque boost 2 (Function 65) and electronic thermal overload relay 2 (Functions 66 and 67) are also selected simultaneously.

3 = Terminal X4-P24 functions as a 'hold' (HLD) signal for operating commands, *ie* RUN inputs are latched when a pulsed signal is given at FWD/REV-P24.

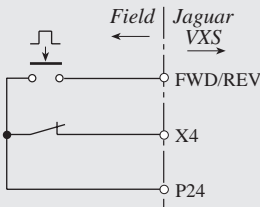

Example: Function 43 = 3.
Pulse FWD/REV-P24 to RUN.
Open X4-P24 to STOP.

44 Preset speed 8

45 Preset speed 9

46 Preset speed 10

47 Preset speed 11

48 Preset speed 12

49 Preset speed 13

50 Preset speed 14

51 Preset speed 15

These Functions can be activated only if Function 43 = 1.

All selections using terminals X1, X2, and X3 remain available, with the additional selections shown in the table below.

Func.	Frequency setting	X1	X2	X3	X4
44	Preset speed 8	<input type="checkbox"/>	<input type="checkbox"/>	<input type="checkbox"/>	<input checked="" type="checkbox"/>
45	Preset speed 9	<input checked="" type="checkbox"/>	<input type="checkbox"/>	<input type="checkbox"/>	<input checked="" type="checkbox"/>
46	Preset speed 10	<input type="checkbox"/>	<input checked="" type="checkbox"/>	<input type="checkbox"/>	<input checked="" type="checkbox"/>
47	Preset speed 11	<input type="checkbox"/>	<input checked="" type="checkbox"/>	<input type="checkbox"/>	<input checked="" type="checkbox"/>
48	Preset speed 12	<input type="checkbox"/>	<input type="checkbox"/>	<input checked="" type="checkbox"/>	<input checked="" type="checkbox"/>
49	Preset speed 13	<input checked="" type="checkbox"/>	<input type="checkbox"/>	<input checked="" type="checkbox"/>	<input checked="" type="checkbox"/>
50	Preset speed 14	<input type="checkbox"/>	<input checked="" type="checkbox"/>	<input checked="" type="checkbox"/>	<input checked="" type="checkbox"/>
51	Preset speed 15	<input checked="" type="checkbox"/>	<input checked="" type="checkbox"/>	<input checked="" type="checkbox"/>	<input checked="" type="checkbox"/>

■ = ON □ = OFF

52 Frequency reference filter

Setting range 0.0s to 5.00s in steps of 0.02s.

Function 52 sets the time constant for the digital input filters to eliminate the effect of electronic 'noise' on the analog signals and control inputs.

If the time constant is too long, the system lag may become unacceptable.

53 Operation timer

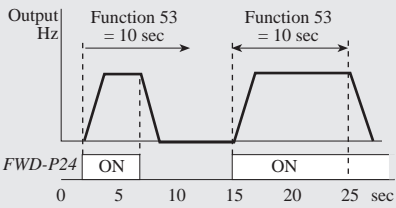

Sets the duration of an operation in seconds from the time it is initiated. At the end of the period, the inverter will stop and wait for a RUN command (FWD/REV-P24 = ON). If a RUN command is removed before the timer has timed out, the inverter output will stop, see left-hand side of diagram above.

Setting ranges

- 0.00 = Inactive (Factory-set default)
- from 0.01 to 9.99 in steps of 0.01
- from 10.0 to 99.9 in steps of 0.1
- from 100 to 999 in steps of 1
- from 1000 to 3600 in steps of 10

54 Terminal Y1E functions

Selects the type of output signal provided at terminal Y1E from the following:

- 0 = RUN signal. Inverter active.
- 1 = Output frequency level detection (FDT, refer to Function 55). Terminal output is ON when the output frequency is identical to the frequency set in Function 55. Factory-set default.
- 2 = Output frequency equivalence signal (FAR, refer to Function 56). Terminal output is ON when the frequency reaches the frequency set by the keypad panel, the analog input, or a preset speed, plus or minus the hysteresis, Function 56.
- 3 = Inverter undervoltage trip operated (LU).
- 4 = Inverter torque limiting mode (TL).
- 5 = Auto-restart mode after momentary power loss (IP).

55 Frequency detection level (FDT)

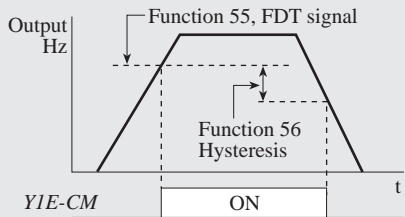

Sets the frequency level in Hz at which the FDT signal is activated during acceleration. During deceleration the signal deactivates at the FDT level minus the hysteresis set in Function 56, as shown in the diagram above.

Factory-set default value is 50.00. Refer also to Function 54, data setting 1.

Setting ranges

- from 0.00 to 99.99 in steps of 0.01
- from 100.0 to 400.0 steps of 0.1

56 Hysteresis for FDT or FAR

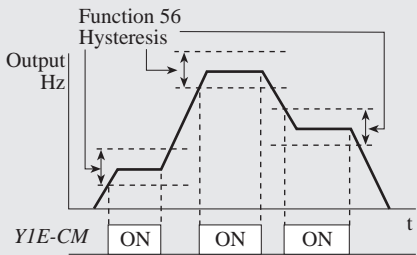

Sets the hysteresis bandwidth for both the FDT and the FAR Functions as shown in the diagrams above. Setting range is 0 to 30Hz in steps of 1Hz. Factory-set default 10Hz. The frequency equivalence is at the mid-range of the hysteresis setting.

Refer also to Function 54 data = 1 or 2.

WARNING For certain applications, eg lifts, hoists etc, Functions 55 & 56 may be used to de-energise a fail-safe electro-mechanical brake system *via* output terminal Y1E. **It is essential** that Function 56 is set correctly with respect to the required FDT level, Function 55, prior to operation.

57 Terminal THR function

Terminal THR is normally used as an external trip. In addition, Function 57 permits the use of this external circuit to give increased data security in conjunction with Function 00 as shown in the table below. The circuit could, for example, be equipped with a key-switch contact.

Setting range

0 = THR (external trip circuit) function

1 = Additional data protection function

The relationship of Function 57 and Function 00 is shown in the table below.

When Function 57 = 1:

THR-P24	Function 00	Data adjustable?
OPEN	= 0	NO
OPEN	= 1	NO
CLOSED	= 0	YES
CLOSED	= 1	NO

58 Skip frequency hysteresis

59 Skip frequency 1

60 Skip frequency 2

61 Skip frequency 3

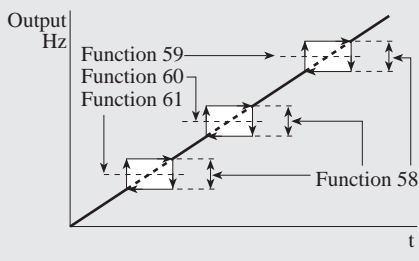

Up to 3 frequencies can be set so that during acceleration and deceleration the inverter output jumps from one level to another to avoid any frequencies that give rise to mechanical resonance. The hysteresis bandwidth is the same for all. The skip frequencies are at the mid-point of the hysteresis band.

Setting ranges

Hysteresis: 0Hz to 30Hz
in steps of 1Hz

Skip frequencies: 0Hz to 400Hz
in steps of 1Hz

Factory-set defaults are:

hysteresis 3Hz, skip frequencies 0Hz.

NOTE Skip frequency 1 may be lower or higher than skip frequency 2 and/or 3. Values need not correspond to the numerical sequence.

62 Base frequency 2

For Motor 2 only. Refer also to Function 04.

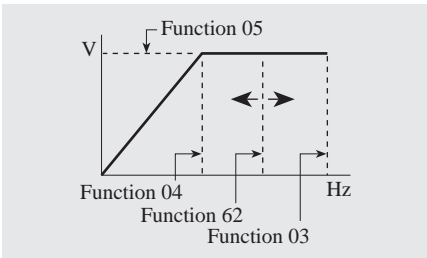

The output voltage and frequency of the inverter are proportional up to base frequency, giving a theoretically constant torque output.

NOTES

- 1 If base frequency is set higher than maximum frequency (Function 03), the output voltage cannot rise to rated voltage.
- 2 When Function 43 = 2, activating terminal X4-P24 selects Base frequency 2 **and also Functions 63, 64, 65, 66 and 67 automatically.**

63 Acceleration time 2

64 Deceleration time 2

For Motor 2 only. Refer also to Functions 06, 07 and 43. Accel. time 2 and Decel. time 2 are selected by activating terminal X4-P24 when Function 43 = 0 or 2.

Factory-set default values are 10 seconds for both acceleration and deceleration. Accel. time 2 and Decel. time 2 can be set independently in the range from 0.1 (F63/64 = 0.00) to 3600s.

When Function 63 or 64 setting = 0.00, the acceleration or deceleration time is 0.01 sec.

NOTE When Function 43 = 2, activating terminal X4-P24 selects Accel. time 2 and Decel. time 2 **and also Functions 62, 65, 66 and 67 automatically.**

65 Torque boost 2 (non-auto)

For Motor 2 only. Refer also to Function 08.

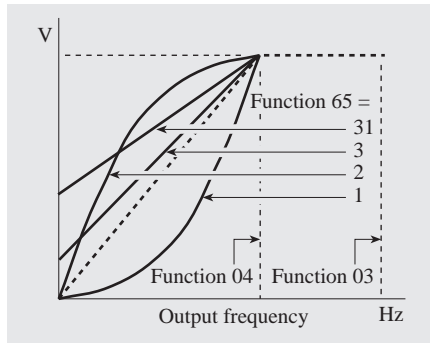

The factory-set default value of Function 65 is 13.

Automatic boost (equivalent to Function 08 = 0) is not available.

When Function 65 is set to 1, the boost applied is proportional to the square of the speed (frequency) — a suitable characteristic for fans and centrifugal pumps.

When Function 65 is set to 2, the boost is proportional to the torque demand.

Linear boost, inversely proportional to speed, is applied when Function 65 = 3 (low boost) increasing in unit steps to high boost when Function 65 = 31.

- 1 = Squared characteristic (for pumps and fans)
- 2 = Proportional characteristic
- 3 = Low linear boost...
- ...increasing in unit steps to...
- 31 = High linear boost

NOTE When Function 43 = 2, activating terminal X4-P24 selects Torque boost 2 **and also Functions 62, 63, 64, 66 and 67 automatically.**

For Motor 2 only. Refer also to Function 15.

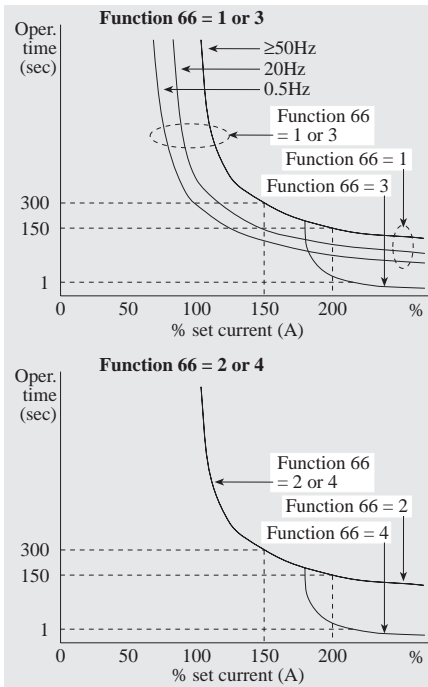

There are five modes of the Function 66:

0 **Inactive.**

1 or 3 **Active.** The factory-set default — suitable for 'standard' 4-pole induction motors.

2 or 4 **Active.** For inverter-rated motors.

Characteristic curves for the settings of Function 66 = 1, 2, 3, 4 are shown above.

NOTE When Function 43 = 2, activating terminal X4-P24 selects Thermal overload 2 **and also Functions 62, 63, 64, 65 and 67 automatically.**

For Motor 2 only. Refer also to Function 16.

Factory-set default level is at 105% of the current rating of a standard 4-pole induction motor appropriate to the capacity of the inverter. If it is intended to use the inverter to drive a motor of a different frame size, refer to Function 70.

Example 1: For a VXS400-3 4kW inverter driving a 4-pole 2.2kW motor at 415V:

Inverter FLC = 9A

Typical 2.2kW motor FLC = 4.8A

Setting for Function 67 = 4.8

Check: $\frac{\text{Motor FLC}}{\text{Inverter FLC}} = \frac{4.8}{9.0} = 0.533$ or 53.3%

which is within the range of 20-105% of **inverter** FLC and the motor is protected.

Example 2: For a VXS400-3 4kW inverter driving a 4-pole 0.37kW motor at 415V:

Inverter FLC = 9A

Typical 0.37kW motor FLC = 1.08A

Setting for Function 67 = 1.08

Check: $\frac{\text{Motor FLC}}{\text{Inverter FLC}} = \frac{1.08}{9.0} = 0.12$ or 12%

This is outside the 20-105% range and the motor **is not protected** by the inverter. A stand-alone thermal protection relay should be wired to the motor thermistor. Then set Function 66 = 0 to disable Function 67.

NOTE When Function 43 = 2, activating terminal X4-P24 selects Thermal overload 2 **and also Functions 62, 63, 64, 65 and 66 automatically.**

68 Slip compensation

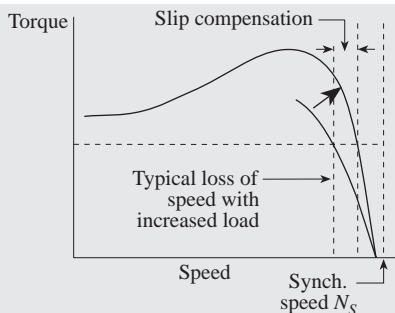

Setting ranges 0 = Inactive
 0.1Hz to 5.0Hz.

When the motor loading increases, the motor slows down. Conversely, if load reduces, speed increases. The object of slip compensation is to keep the motor speed constant under varying load.

As illustrated above, slip compensation raises the motor speed to compensate for a load torque increase. Function 68 sets the 'compensation frequency' C_f for slip compensation.

The exact value for the % slip at full load will vary from one motor to another.

Example: Typical rating plate data:

Number of poles $p = 4$;

Base frequency $f = 50\text{Hz}$;

Shaft rotational speed at full load, $N_L = 1420\text{rpm}$.

Calculated synchronous speed (*ie* the speed of the rotating field in rpm), N_S :

$$N_S = \frac{f \times 120}{p} = \frac{50 \times 120}{4} = 1500\text{rpm}$$

$$\begin{aligned} \text{Set Function 68} &= \frac{(N_S - N_L) \times f}{N_S} \\ &= \frac{(1500 - 1420) \times 50}{1500} \\ &= \underline{2.7\text{Hz}} \end{aligned}$$

69 Torque vector control

Motor 1 only.

Setting range

- 0 = Torque vector control inactive, and standard V/f control applies.
- 1 = Torque vector control active.

To obtain the maximum amount of motor torque under a variety of operating conditions, the output torque is accurately calculated by the inverter software in accordance with load conditions. The voltage vector is controlled to the optimum value based on the result of the calculation. Torque vector control can only be used for Motor 1. The motor capacity must be within the vector control range for the inverter. Refer to Function 70.

NOTES

- 1 If torque vector control is selected it is advisable to use the Automatic Tuning facility, Function 74, wherever possible, for optimum control of the driven load.
- 2 If Function 43 = 2 (X4 terminal VF2 function), torque vector control is inactive. Torque boost 2 is applied.

70 Motor 1 capacity

Motor 1 only.

Compensates for a motor of capacity different from that of the inverter.

Setting ranges

- 0 = Motor capacity one frame size above inverter capacity.
- 1 = Equal ratings.
- 2 = Motor capacity one frame size below inverter capacity.
- 3 = Motor capacity two frame sizes below inverter capacity.

71 Motor 1 rated current

72 Motor 1 no-load current

Motor 1 only.

Setting range

0.01 to 99.9 amps

Functions 71 and 72 are preset for a motor of nominal rating equal to the inverter rating, but

may require fine tuning. For a motor of frame size different to that of the inverter, Functions 71 and 72 will require adjustment.

For Function 71, use the rating plate data. Function 72 can be approximated from:

$$I_O = I_T \times \sqrt{[1 - (\cos\phi)^2]}$$

73 Motor 2 rated current

Motor 2 only.

Setting range 0.01 to 99.9 amps

For a standard 4-pole motor. Selected when Function 62, base frequency 2, is active.

74 Automatic tuning

Motor 1 only.

Setting range 0 = Inactive
1 = Active

Provides for auto-tuning the inverter to the primary resistance and the leakage reactance of a motor and its cable. The motor must be correctly connected to the inverter, and the inverter must be in STOP mode. Set Function 74 = 1 and press the FUNC/DATA key. Tuning will be completed in about 10 seconds. The display reads 'F 75' when tuning is complete.

The results of the auto-tuning can be inspected and changed in Functions 75 and 76 if desired.

NOTES

- 1 **It is essential that motor 1 capacity, Function 70, is correctly set prior to tuning.**
- 2 If BX-P24 is closed, auto-tuning is not possible.
- 3 If the auto-tuning procedure is not successful (may happen with non-standard motors), code Er7 will be displayed on the keypad. In this event, tune manually using Functions 75 and 76.
- 4 The *Jaguar VXS* does not measure motor magnetising current (entered manually, Function 72), therefore the motor does not rotate during tuning.
- 5 Auto-tuning may be unsuccessful, and manual tuning will be required if:
 - a) the motor line is open-circuited;
 - b) the motor line length is >50m;
 - c) output inductors are fitted.

75 Impedance %R setting

76 Impedance %X setting

CAUTION %R and %X should be set to values appropriate for the motor to be used, otherwise the motor may not operate correctly and there may be a risk of damage.

Motor 1 only.

Function 75 — %R

Setting range

0.00 to 50.0% in steps of 0.01%

NOTE The R_1 and R_{cable} values for a motor and its supply cable can be directly measured (star or delta) using a multimeter.

This Function allows the manual insertion of a value for the percentage resistive impedance of the motor. If Function 74, auto-tuning, is used first and is successful the %R value will be shown in Function 75.

To calculate %R, the following expression may be used (for star-connected motors):

$$\%R = \frac{\sqrt{3} \cdot I \cdot (R_1 + R_{\text{cable}})}{V} \times 100$$

where I is the rated full load current of a star-connected motor,

V is the motor rated voltage, Function 05, (= line voltage V_L)

and R_1 and R_{cable} values are in ohms.

Function 76 — %X

Setting range

0.00 to 50.0% in steps of 0.01%

NOTE The results of tuning to the primary reactance are stored in Function 76 and can be examined after the auto-tune function. However, if necessary, the %X value can be calculated and entered manually into Function 76.

Users are advised to consult the manufacturer of the motor to obtain the motor 'equivalent circuit' parameters to use as shown in the example on the following page.

To calculate the value of motor circuit reactance, %X

The data necessary for the calculations:

Motor rating plate data:

$$V = \text{Rated voltage (Function 05)} = 415V$$

$$I = \text{Rated FLC of the motor} = 1.93A$$

Manufacturer's data for the equivalent circuit:

$$X_1 = \text{Stator reactance} = 8.161\Omega$$

$$X_2 = \text{Rotor reactance (referred to stator)} = 8.913\Omega$$

$$X_M = \text{Magnetising reactance} = 171.3\Omega$$

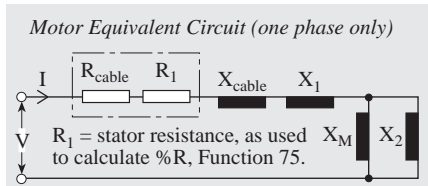

NOTE It is **essential** to check that the data provided by the manufacturer is for a star-connected motor.

The working

Data for the cable chosen for this example:

4-core, cross-sectional area 4mm^2 , distance between conductors 3mm , length 30m .

Distance between conductors should be obtained from the cable manufacturer.

To calculate X_{cable} :

first determine cable inductance L in Henries per metre (H/m) from:

$$L = 10^{-7} \cdot 4 \log_e \frac{d}{r}$$

where d is the distance between the conductors

and r is the radius of a conductor, from:
radius $r =$

$$\sqrt{[(\text{conductor cross-sectional area}) \div \pi]}$$

$$= 1.13\text{mm}$$

Dimensions must be in consistent units.

$$\text{So, } L = 10^{-7} \cdot 4 \cdot \log_e \frac{3}{1.13} \text{ H/m}$$

$$= 10^{-7} \cdot 3.905 \text{ H/m}$$

To convert to Ω/m , multiply by 100π

$$\therefore X_{\text{cable}} = 100\pi (10^{-7} \cdot 3.905) \text{ } \Omega/\text{m}$$

$$= 1.23 \cdot 10^{-4} \text{ } \Omega/\text{m}$$

For a 30m cable,

$$X_{\text{cable}} = 30 \cdot 1.23 \cdot 10^{-4} \text{ } \Omega/\text{m}$$

$$= 0.0037 \text{ } \Omega$$

The calculated value of X_{cable} is insignificant in relation to the other values (in this example) and could be ignored.

Calculation of motor %X

In the following expression:

$$\%X = \frac{[(X_2 \cdot X_M) / (X_2 + X_M)] + (X_1 + X_{\text{cable}})}{V / (\sqrt{3} \cdot I)} \times 100$$

Substitute the values for X_1 , X_2 , X_{cable} :

$$\%X = 100 \times \frac{[(8.913 \cdot 171.3) / (8.913 + 171.3)] + (8.161 + 0.0037)}{415 / (\sqrt{3} \cdot 1.93)}$$

$$= \underline{13.4}$$

Set Function 76 = 13.4

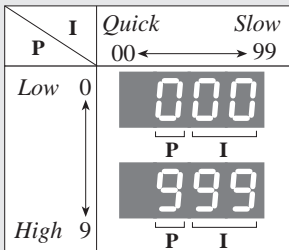
77 Torque limiter, constant speed**78 Torque limiter, accel./decel***Setting range*

000 to 999 in unit steps

Factory-set defaults:

Torque limiter at constant speed: 369;

Torque limiter during acceleration and deceleration: 394.

79 Option selector

Function 79 is used to configure the inverter correctly when one of the following options is installed:

- 0 No options
- 1 DI option card
- 2 DI/O option card
- 3 RS option card

For details of options, please refer to IMO Precision Controls Ltd.

8 Troubleshooting

8.1 Electronic Protection

When a trip occurs, the inverter will remain disabled (provided that the restart function is not in use, refer to Functions 13 and 14) until the conditions that caused the trip are removed and the inverter is reset by pressing the PRG/RESET key or applying a reset command input at terminal RST.

NOTE If the electronic protection acts to trip the inverter, investigate the cause of the trouble by using the appropriate flow diagram on the following pages. If you cannot identify and correct the problem in this way, or if you think the inverter may have been damaged, please consult IMO Precision Controls Ltd.

8.2 Trip Alarm Functions

All protective functions cause a trip code to be displayed on the 7-segment LEDs panel.

All protective functions operate the internal trip/alarm relay to close circuit (30A)-(30C) and open circuit (30B)-(30C).

Output terminal Y1E can be used to signal externally that the inverter has tripped on undervoltage. Refer to Function 54.

Effects of a trip

- Inverter output stops
- Motor coasts to rest
- Trip code displayed and retained in memory
- Alarm relay change of state

NOTES

1 *Alarm signal holding*

If the power supply to the inverter is switched off automatically or otherwise after a protective function has operated, the internal control power supply is lost and the outputs at the alarm relay (30A/B/C) and terminal Y1E are lost also.

2 *Trip code memory*

Trip codes of the four last trips are stored in memory and are not affected by loss of the power supply.

8.3 Trip Alarm Codes

- OC1 **Overcurrent trip during acceleration**
- OC2 **Overcurrent trip during deceleration**
- OC3 **Overcurrent trip at steady speed**

Protects the inverter against momentary overcurrent, short circuits or earth faults occurring internally and in the motor circuit.

OLU **Overload trip**

Protects the inverter against overloading of the inverter output devices (IGBTs).

OL **Overload trip**

Electronic thermal overload. Protects a standard 4-pole motor against overload.

OU1 **Overvoltage trip during acceleration**

OU2 **Overvoltage trip during deceleration**

OU3 **Overvoltage trip at steady speed**

Operates if the DC bus voltage exceeds the overvoltage detection level because of regeneration. Does not operate or protect against excessive supply input voltage.

OH1 **Inverter overtemperature trip**

Protects the inverter against overheating caused by overloading, high ambient temperature, or cooling fan failure.

OH2 **External alarm input trip**

Operates when a trip command signal is input at terminal THR.

LU **Undervoltage trip**

Trips the inverter if the supply voltage falls below 165V for 1-phase inverters (310V for 3-phase inverters).

The inverter is designed to 'ride through' if the voltage dip is momentary ($\leq 15\text{ms}$ at full 'motoring' load). However, if the load is of high inertia, the ride-through time could be substantially greater. For further information please consult IMO Precision Controls Ltd.

Er1 **Memory error**

Er2 **Keypad communication error**

Er3 **CPU error**

Er4 **Option card checksum error**

Er5 **Serial communications link error**

Er7 **Error during auto-tuning**

WARNING The inverter may restart automatically after an overcurrent or overvoltage trip. Refer to Functions 13 and 14.

8.4 Troubleshooting Flow Diagrams

NOTE Although it is impossible to foresee every eventuality, the diagrams on the following pages will be found to cover the more common problems. If further assistance is required, please consult IMO Precision Controls Ltd.

○ STATUS ◇ ? QUERY □ ACTION

Overcurrent trip OC1, OC2, OC3

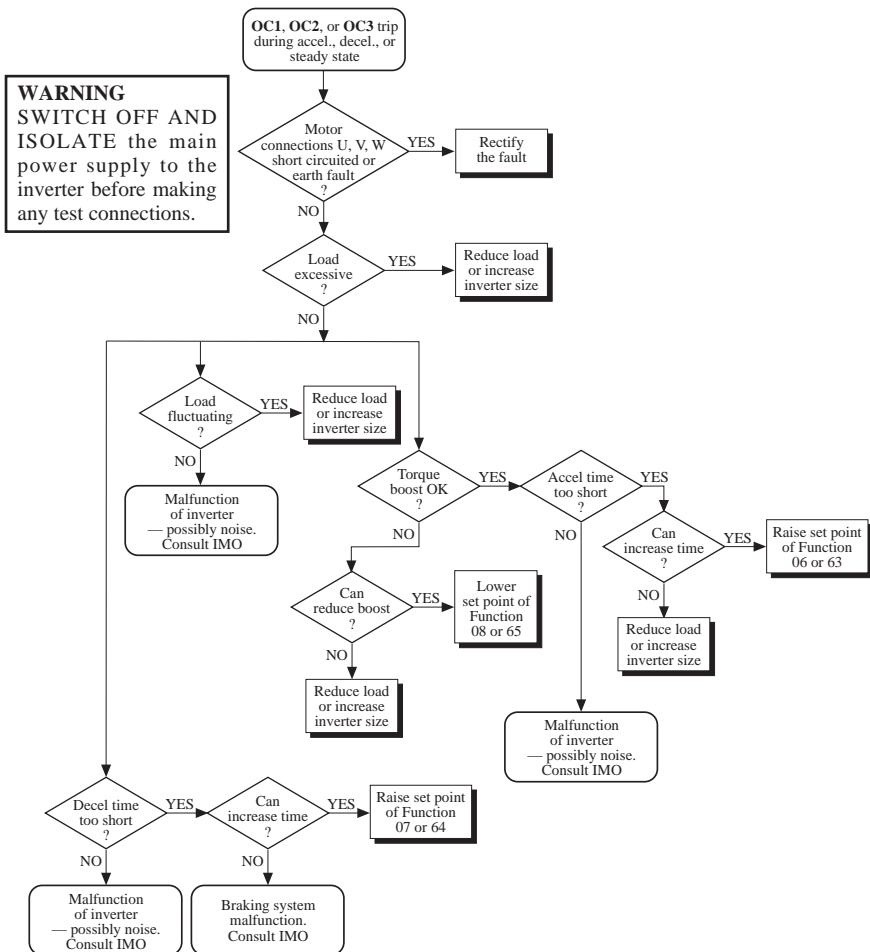

Undervoltage trip LU

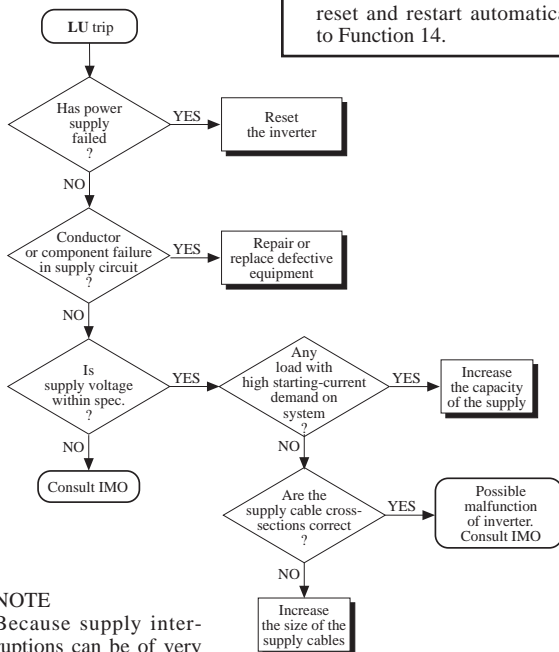

WARNING

If the power supply is automatically restored after a failure, the inverter may reset and restart automatically. Refer to Function 14.

NOTE

Because supply interruptions can be of very short duration, an oscilloscope or other dedicated equipment may be required to detect mains dip or loss.

Motor overload OL Inverter overload OLU

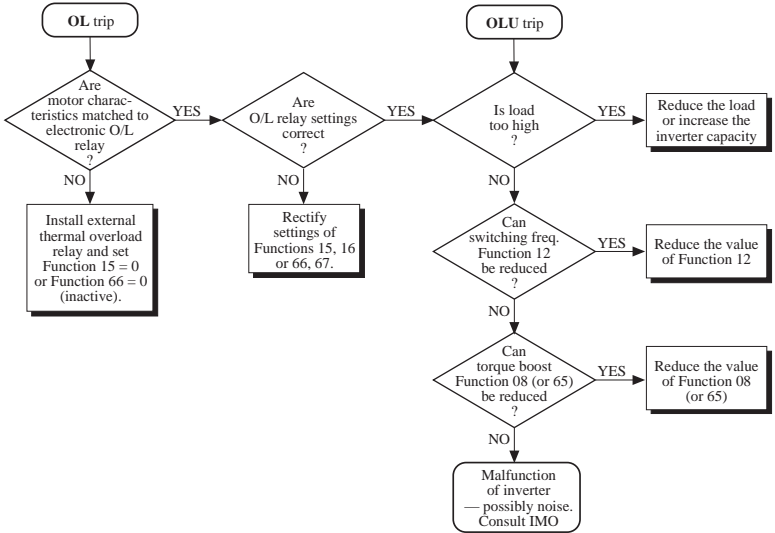

External trip alarm input OH2

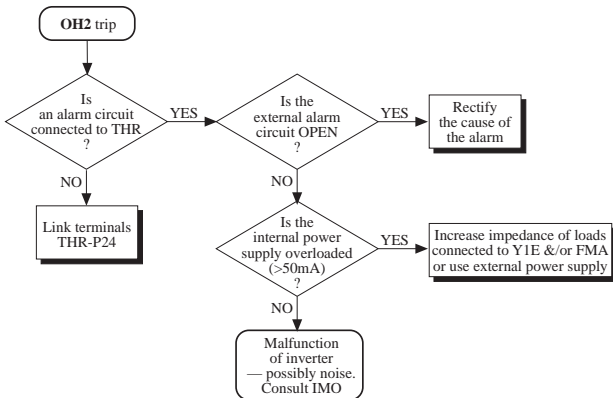

Inverter overtemperature OHI

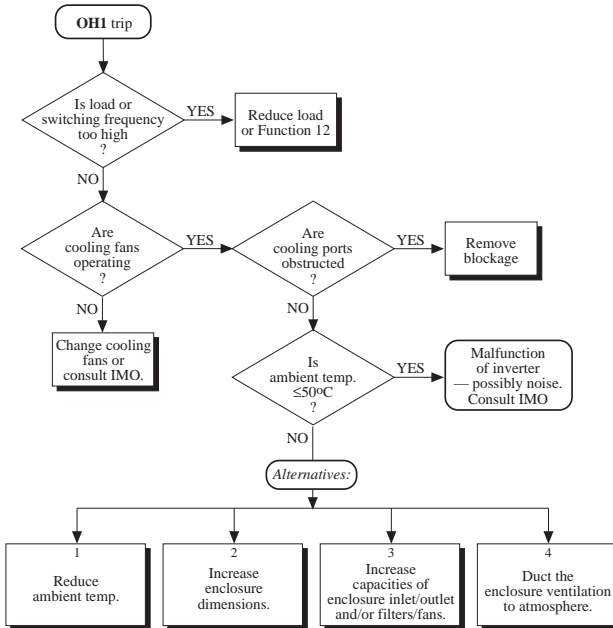

Overvoltage trip OU1, OU2, OU3

WARNING
If the power supply is automatically restored after a failure, the inverter may reset and restart automatically. Refer to Function 14.

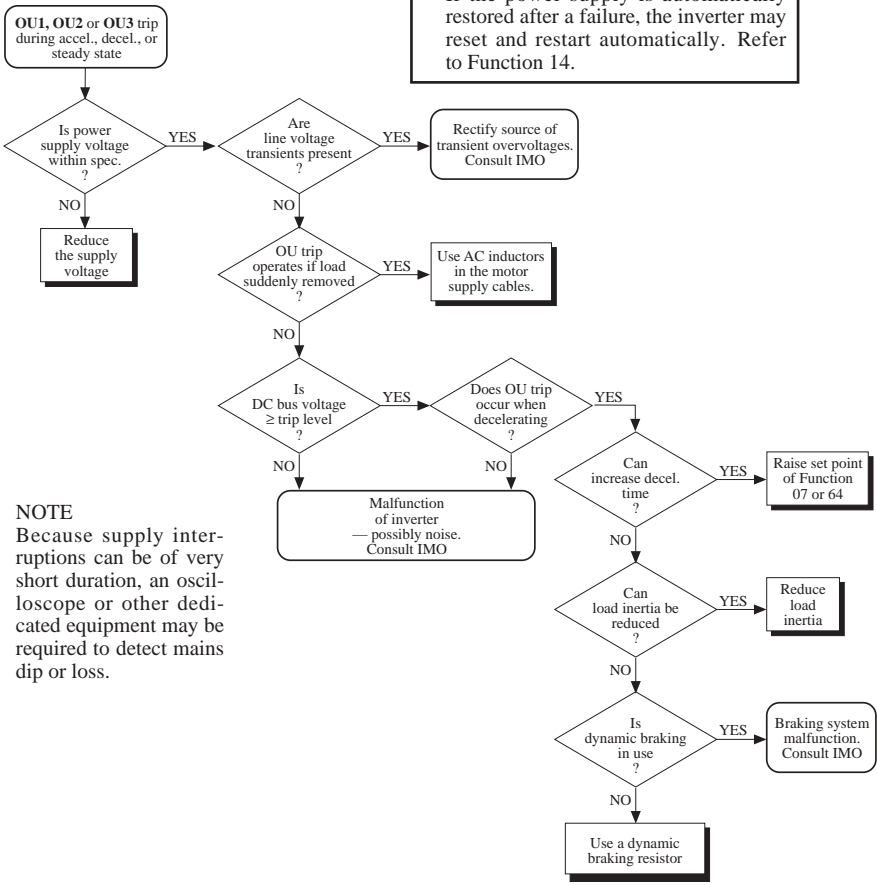

NOTE
Because supply interruptions can be of very short duration, an oscilloscope or other dedicated equipment may be required to detect mains dip or loss.

For VXS20-1 inverters, please refer to IMO Precision Controls Ltd.

Memory error Er1 Communication error Er2 CPU error Er3

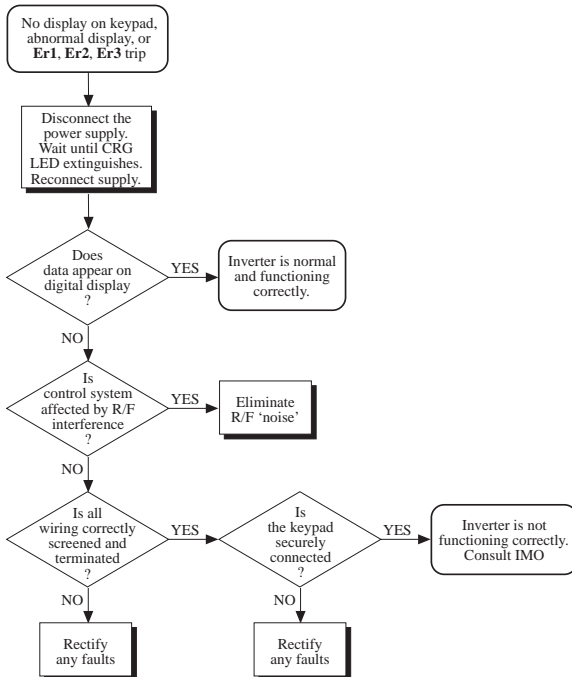

Inverter auto-tuning error Er7

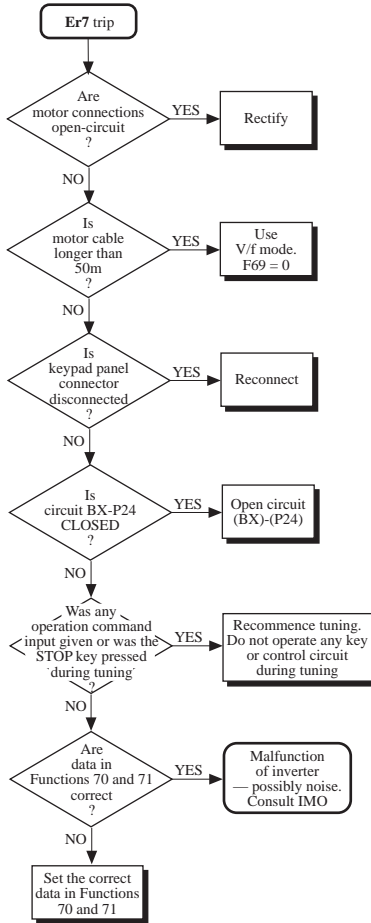

Motor does not run

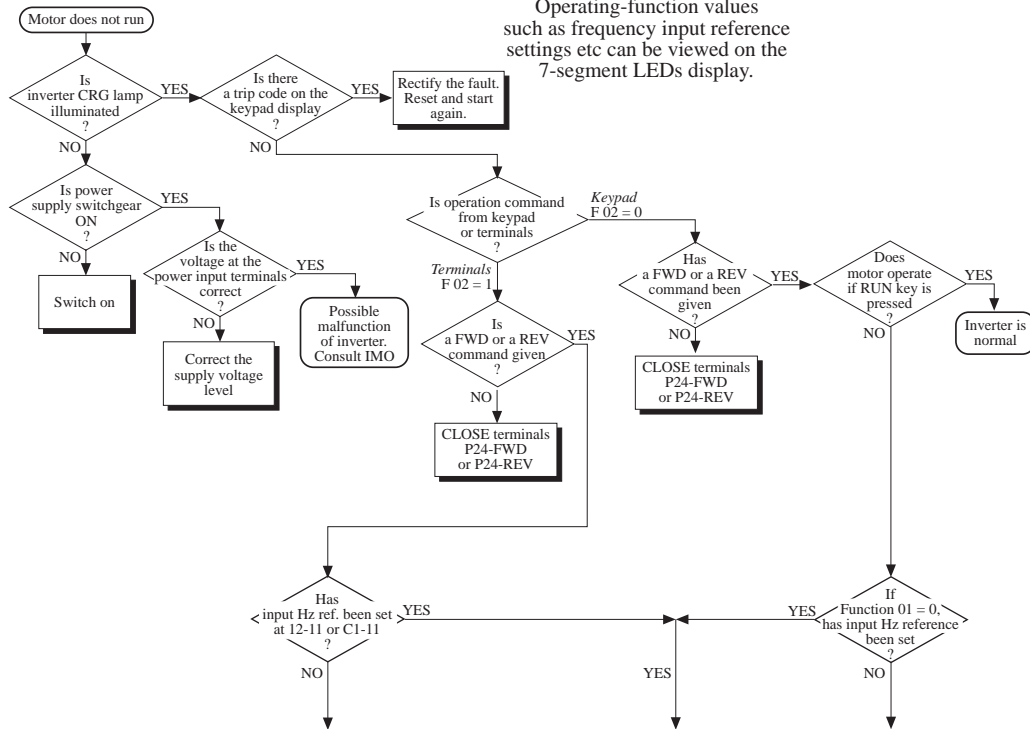

NOTE
 Operating-function values such as frequency input reference settings etc can be viewed on the 7-segment LEDs display.

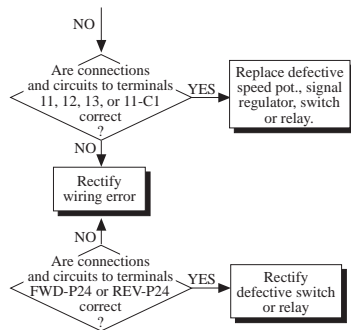

NOTES

- 1 If an external normally-open contact is not installed to provide a RUN command signal, terminals FWD-P24 or REV-P24 must be linked.
- 2 If an external normally-closed protection contact is not installed, terminals THR-P24 must be linked.
- 3 If a mechanical or electro-mechanical brake is fitted to the motor, first ensure that the brake lifts correctly when a motor RUN command is input.
- 4 The motor may in any case not start if —
 - A RUN command is input when the motor is coasting to rest on a BX-P24 command input;
 - A RUN command is input whilst a DC injection braking command is active;
 - Unsuitable values have been applied to Functions 04, 05, 08, 65, 70, 71, 72, 73, 75 or 76.

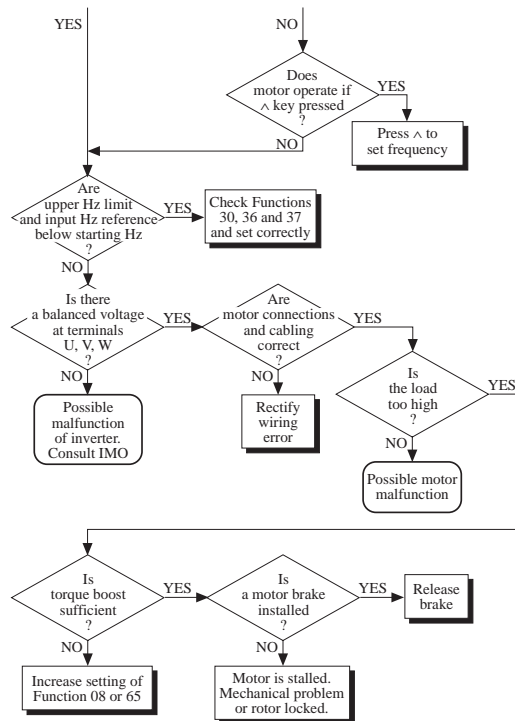

STATUS

QUERY

ACTION

○ STATUS

◇ ? QUERY

▭ ACTION

Motor overheats

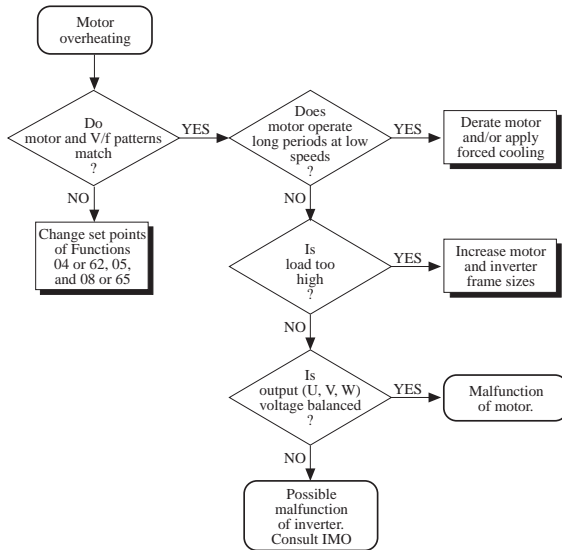

9 Braking

9.1 Introduction

When a rotating mass is electrically braked to a standstill by reducing the frequency of the supply at the motor terminals, the motor effectively assumes the characteristics of an asynchronous generator for at least some period of the deceleration time. The kinetic energy of the load is converted by the motor to electrical energy.

As the input-side rectifier of the inverter is not designed to deliver current into the supply system, the voltage of the inverter DC bus is thus caused by the regeneration to increase, and may rise to an unacceptable level if not controlled. The inverter would then trip (overvoltage trip code OU). Control of deceleration would be lost; the motor would be freewheeling.

The DC bus can absorb, typically, between 3% and 5% of regenerative power, equivalent to normal heat losses when driving.

To absorb higher levels of regenerative energy it is necessary to convert excess DC voltage into heat by delivering the regenerative current to a resistor in short pulses controlled by transistor switching.

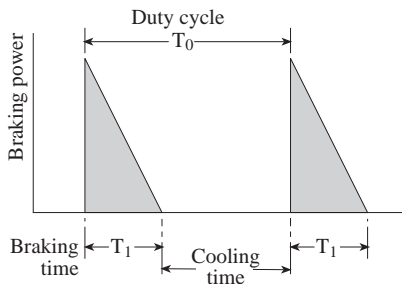

The factors which influence the amount of regenerative power to be dissipated are:

- The speed of the motor and load in rpm;
- the inertia of the motor and load, $J_M + J_L$;
- the deceleration rate, $\Delta\omega/\Delta t$.

The rating of the resistor will depend on the duty cycle, illustrated above.

9.2 Overhauling Loads

WARNING Inverter braking functions are not a substitute for mechanical braking devices designed to ensure safety.

The braking components may be active not only when a high inertia load is being decelerated but also when the regenerative period has to be constant and prolonged, as in a hoisting application when the load, which may be up to the maximum for which the inverter is rated, must be lowered at a controlled speed.

In this case, the mass of the load would attempt to overspeed the motor for a large part of the duty cycle, again with the consequence that the DC bus voltage would become excessive. Obviously, it would be dangerous to permit the inverter to trip, as the load would then be out of control.

Careful consideration must be given to the selection of the resistor to be of adequate capacity for this duty.

A worked example of calculations for the ohmic rating and power (capacity kW) of a braking resistor is given on the following page.

NOTES

- For an external braking circuit, Function 33 must be set to 1.
- Attention is drawn to the table of minimum braking resistor values on the following page.**

9.3 Calculations for Braking Resistors

The data necessary for the calculations:

Inverter Jaguar VXS 150-1, (1.5kW, 240V 1-phase)

Motor* Rated power, $P = 1.5\text{kW}$
Speed, $N_L = 1420\text{rpm}$
Inertia, $J_M = 0.0035\text{ kg m}^2$

Load* Inertia, $J_L = 0.205\text{ kg m}^2$
Resistive torque $M_R = 0.49\text{ Nm}$

*Manufacturers' data

Maximum DC bus voltage

Nominal DC bus voltage = AC input line voltage multiplied by $\sqrt{2}$. A margin above nominal voltage is necessary to allow for the switching level of the braking transistor.

\therefore Max. DC bus voltage is:

$$(240 \times \sqrt{2}) + 40 = 380\text{V DC}$$

Desired braking performance

Duty cycle = 30 seconds

Deceleration time to standstill (ramp down), $\Delta t = 2\text{ seconds}$

The working:

Angular shaft speed, ω_N

$$\omega_N = \frac{2\pi N_L}{60} = \frac{2\pi \times 1420}{60} = 148.7\text{ rad/s}$$

\therefore maximum torque

$$= \frac{P}{\omega_N} = \frac{1500}{148.7} = 10.08\text{ Nm}$$

Total system inertia J_T

$$J_T = J_M + J_L = 0.2085\text{ kg m}^2$$

and required braking torque, $M_b =$

$$J_T \times \frac{\Delta\omega}{\Delta t} = 0.2085 \times \frac{148.7}{2} = 15.5\text{ Nm}$$

Motor braking torque

$$M_M = M_b - M_R = 15.01\text{ Nm}$$

Instantaneous braking power

$$P_b = M_M \times \omega_N \\ = 15.01 \times 148.7 = 2232\text{ W}$$

Average power during one cycle (rating of the resistor)

$$= 2232 \times \frac{2}{30} = \underline{149\text{W}}$$

Resistor ohmic value

$$= \frac{(\text{DC bus max. V})^2}{P_b} = \frac{380^2}{2232} = \underline{65\Omega}$$

These are the optimum values for the resistor to be selected. As resistors are manufactured in standard sizes, choose a rating of 150W or above, and the closest ohmic value to 65 Ω .

For further advice, and for a supply of braking resistors, please consult IMO Precision Controls Ltd.

CAUTION The Jaguar VXS inverter **will be damaged** if a braking resistor is applied having an ohmic value less than the appropriate minimum shown in the table below.

9.4 Minimum Braking Resistor Values

Inverter type	VXS...	20-1	40-1	75-1	150-1	220-1	40-3	75-3	150-3	220-3	400-3
Rating	Ω	NA	100	100	40	40	200	200	160	160	130

9.5 Protection Circuits

CAUTION When using an external braking resistor, it is **essential** that a series-connected thermal overload trip circuit is installed and that it opens the **main power supply switch** if a braking overload occurs.

Typical Single-phase Protection

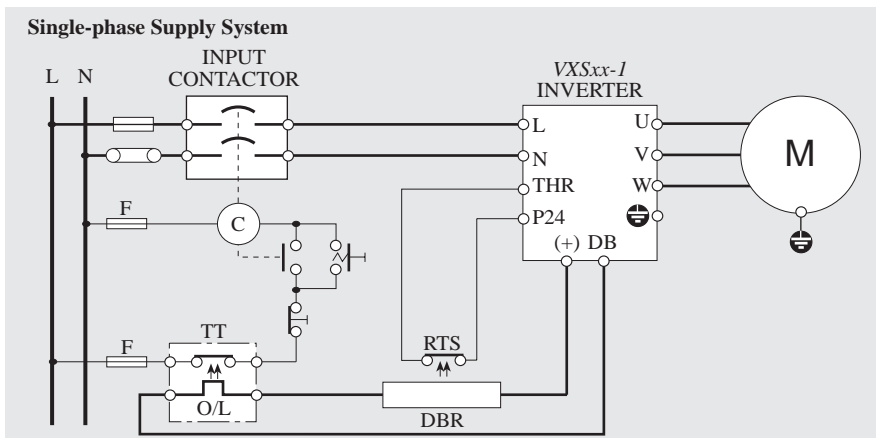

Typical Three-phase Protection

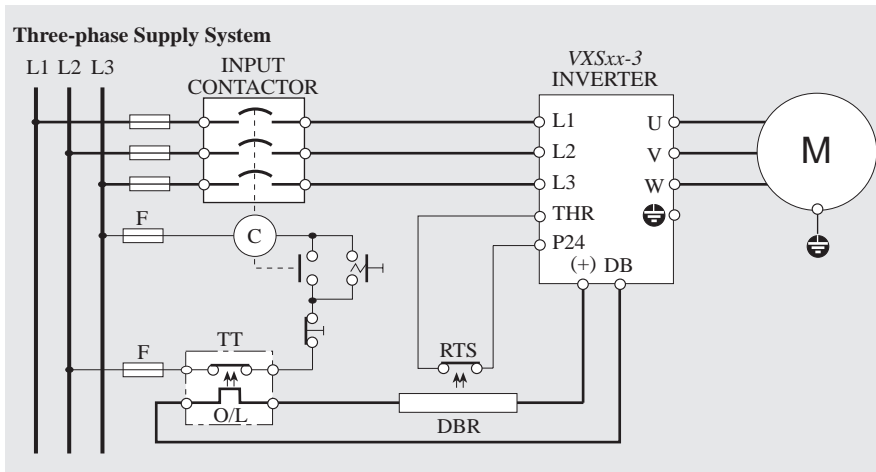

NOTES

- 1 Screening and filtering for EMC is omitted for clarity.
- 2 Observe correct polarity and connections.

KEY

- DBR Braking resistor
 F Control circuit fuses
 O/L Series-connected thermal overload sensor
 RTS Resistor temperature sensor
 TT Thermal trip switch

10 EMC, RFI and Filters

10.1 Electromagnetic Compatibility (EMC)

Complex Components

In accordance with the provisions described in the European Commission Guidelines Document on Council Directive 89/336/EEC, IMO Precision Controls Ltd has chosen to classify the *Jaguar VXS* range of inverters as “Complex Components”. The objective of this decision is to enable IMO Precision Controls Ltd to maximise their support for customers’ own implementation of the EC directives.

Classification as a “Complex Component” allows a product to be treated as an “apparatus”, and thus permits *compliance with the essential requirements of the EMC Directive to be demonstrated* to both an integrator of *Jaguar VXS* inverters (a constructor of switchboards, for example) and to his customer or the installer and the user.

Standards and Marking

It is intended that *Jaguar VXS* inverters be supplied with a CE-marked declaration of conformity, signifying compliance with EC Directive 89/336/EEC when fitted with specified filter units installed and earthed in accordance with the data in this Product Manual.

The “*EC Declaration of Conformity*”, citing conformity with European Harmonised Standard EN60 947-1, “Specification for Low Voltage Switchgear and Controlgear”, will be available upon application to IMO Precision Controls Ltd.

This specification requires the following performance criteria to be met:

Immunity

Fast transient bursts (IEC801-4)

Electromagnetic (IEC801-3)

Electrostatic disturbances (IEC801-2)

Surges: 1.2 x 50µs (IEC1000-4-5 para. 8/20)

Emissions

EN50081-1 or EN50081-2, as specified in the *EC Declaration of Conformity* related to the inverter.

Normally, *Jaguar VXS* inverters will offer compliance with the more severe level of

EN50081-1 although the less-arduous option of EN50081-2 would be adequate for industrial applications. Reference must, however, be made to the *EC Declaration of Conformity* for precise details, as there are differences between models.

Power Input Filters and Output Ferrites

It is strongly recommended that the appropriate *Jaguar VXS* input filter is used, as shown on pages 59 to 61, to limit RF current flowing into the main supply circuit. Without an input filter a *Jaguar VXS* installation may not meet statutory requirements.

At the time of going to press, it is intended to supply a toroidal ferrite output choke, page 62, with every input filter as an ‘EMC Compliance’ kit.

Electromagnetic Emissions — general

Jaguar VXS inverters contain high-power semiconductor devices which are switched at high speeds to synthesise a near-sinusoidal current waveform across the frequency range of the output. Typically, the transition time from the OFF state to fully-conducting is of the order of 200ns (200 x 10⁻⁹s) for these devices. Such rapidly-changing voltages and currents will generate some degree of electromagnetic emission.

Emissions will be predominantly conducted through the motor cables and the mains supply cables, although some radiated emissions will be detected in close proximity to the drive system.

It is *essential* that precautions are taken both at the design stage and at the time of installation to prevent radio-frequency (RF) emissions from the drive system interfering with sensitive equipment in close proximity.

General Precautions

It is strongly recommended that a metallic Back Plate is used as an earth plane for all the safety earth and EMC earth-bonding connections. This very powerful technique meets all the safety earthing requirements and gives *vastly* improved EMC performance.

- The incoming protective earth conductor should be connected directly to the back-plate, and green-yellow conductors should be taken from individual studs on the Back Plate to the enclosure as required to bond each panel that does not get a guaranteed safety bond through the cabinet structure.
- Remove any paint or other insulating film from the enclosure and the Back Plate, and from the Back Plate at the mounting points for the FP Filter. Refer to the illustration below.
- All metal-bodied components are to be bolted directly to the Back Plate, **metal to metal**. Any safety or other earth conductors should be as short and as thick as possible, and should connect directly from their component to a stud on the back plate close by, with only a single earth connection per stud as directed by EN 60204-1:1993 — the EU harmonised electrical safety standard for the electrical equipment of machines (also the most relevant electrical safety standard for almost all industrial electrical control cabinets which are not installed in explosive atmospheres). Additional guidance on EMC Good Wiring Practice is available from IMO Precision Controls Ltd on application.
- Use the correct filtering equipment and arrangements as recommended by IMO Precision Controls Ltd and illustrated on pages 60, 61 and 62.
- Use screened or armoured cable for the motor supply, taking care to connect the screen to earth at *both* ends as shown in the diagram, right.
- Segregate power cables from control wiring by at least 300mm.
- Avoid parallel cable runs to minimise 'noise coupling'. Wherever runs of power and control cables must cross, try to achieve this at right angles.
- Wherever possible, do not share earth conductors.
- **Important! All conductors between a free-standing RF filter and the inverter MUST be as short and as thick as practicable.**
- Always use screened control wiring. For local control circuits, as illustrated on page 13, terminate the screen at the drive end *only*. If using an external controller (eg a PLC or similar) terminate the screen at the non-drive end.
- Use the lowest possible switching (carrier) frequency that will operate the application satisfactorily. Refer to Function 12, pages 21 and 29.
- **Jaguar VXS inverters should be installed, and are designed to operate, within an electrically-shielded metal enclosure.**

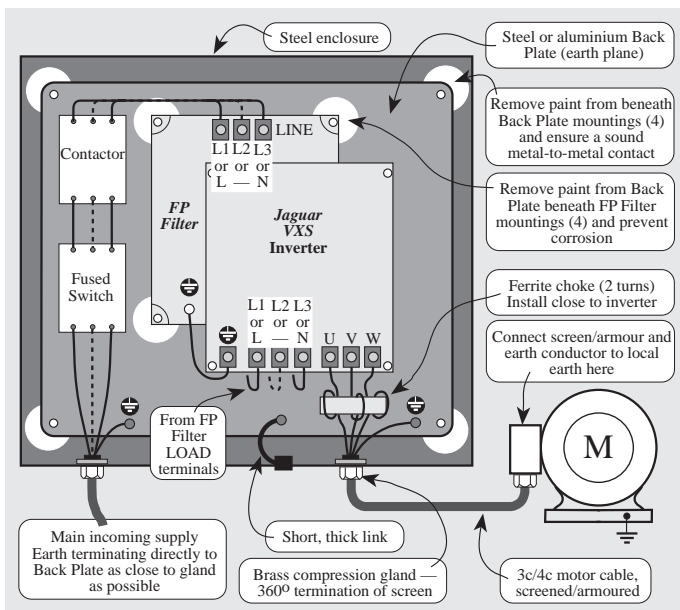

10.2 Single-phase RFI-FP Filter

A *Jaguar VXS* inverter may be mounted on the face of the Flatpack Filter using the integral tapped mounting points. Alternatively, the filter may be mounted upright beside the inverter.

Refer to the diagram on page 59 for details of connections and screening.

Earth Leakage Current

Under normal running conditions, the effective leakage is 3.5mA nominal at 50Hz.

WARNING The RF filter must be earthed in accordance with the appropriate circuit diagram on page 59.

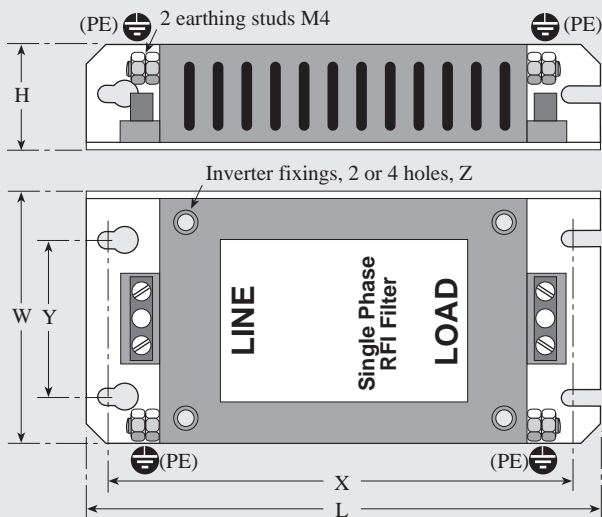
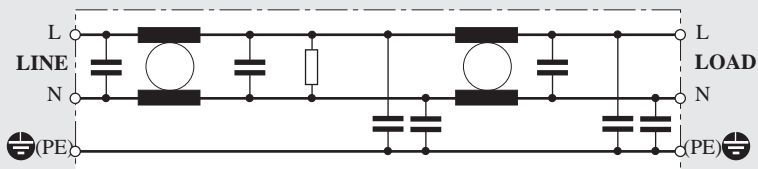

Part number	Jaguar VXS inverter range	Rated current at 40°C	Dimensions (mm)							Weight kg
			L	W	H	X	Y	Z		
RFI 20-1	VXS20-1	3A	200	110	40	190	85	M5	0.5	
RFI 75-1	VXS40-1 to VXS75-1	10A	195	148	40	185	90	M5	0.55	
RFI 220-1	VXS150-1 to VXS220-1	25A	195	207	40	183	142	M5	1.05	

10.3 Three-phase RFI-FP Filter

A *Jaguar VXS* inverter may be mounted on the face of the Flatpack Filter using the integral tapped mounting points. Alternatively, the filter may be mounted upright beside the inverter.

Refer to the diagram on page 59 for details of connections and screening.

Earth Leakage Current

Under normal running conditions, with three phases energised, the effective leakage is 0.5mA nominal at 50Hz. At power-on, however, or if one phase fails, the leakage current may be up to 40mA.

WARNING The RF filter must be earthed in accordance with the appropriate circuit diagram on page 59.

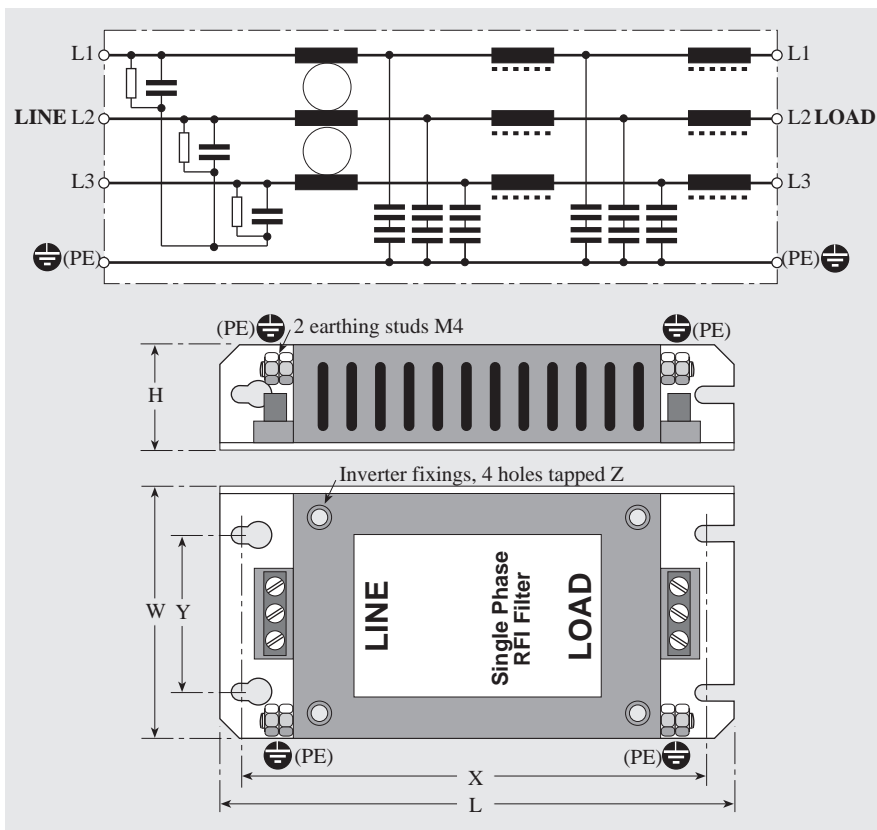

Part number	Jaguar VXS inverter range	Rated current at 40°C	Dimensions (mm)					Weight kg	
			L	W	H	X	Y		
RFI 75-3	VXS40-3 to VXS75-3	10A	195	148	40	185	90	M5	0.95
RFI 400-3	VXS150-3 to VXS400-3	25A	195	207	40	183	142	M5	1.35

10.4 RF Ferrite Physical Data

Part number	Jaguar VXS inverter range	Dimensions (mm)					
		W	H	D	X	Z dia.	d dia.
OC1	VXS20-1, 40-1, 75-1, 40-3, 75-3	85	46	22	70	5	21
OC2	VXS150-1, 220-1, 150-3, 220-3, 400-3	105	62	25	90	5	28.5

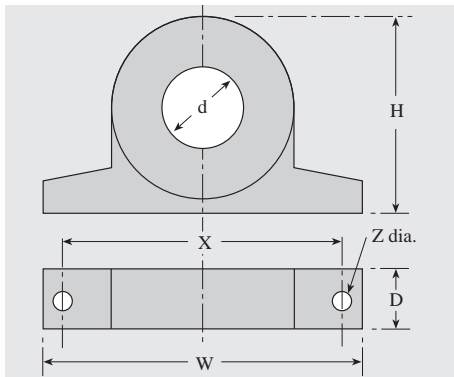

CAUTION

Do not overtighten the fixing screws through the base flanges of the ferrite (at 'Z')

11 Supplementary Data

11.1 Insulation Testing

WARNING

SWITCH OFF AND ISOLATE the main power supply to the inverter before making any test connections.

CAUTION

Do not perform an insulation test on any control circuit terminals.

- 1 **Disconnect the link at the earth terminal** — see NOTE 1 on the diagram.
- 2 Link together terminals as follows —
Single-phase inverters:
L, N, P1, (+), DB, U, V, W. (VXS20-1 inverters do not have a terminal DB.)
Three-phase inverters:
L1, L2, L3, P1, (+), DB, U, V, W.
- 3 Connect the insulation tester as shown. Test voltage applied to the inverter must not exceed 500V DC.
- 4 If the test is satisfactory, remove all temporary links installed in step 2.
- 5 **Reconnect the link to the earth terminal** — see NOTE 1 on the diagram.

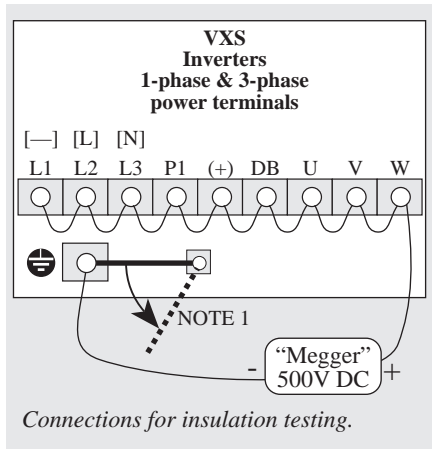

Continuity Testing of Control Circuits

Use a high-resistance tester, not a 'megger' or a buzzer.

11.2 Table of Cable Sizes and Maximum Lengths

<i>Inverter type</i>	VXS...	20-1	40-1	75-1	150-1	220-1	40-3	75-3	150-3	220-3	400-3
----------------------	--------	------	------	------	-------	-------	------	------	-------	-------	-------

Cable Sizes

Mains supply & motor mm ²		1.5	2.5	2.5	4	4	1.5	1.5	2.5	2.5	4
Earth cable mm ²		1.5	2.5	2.5	4	4	1.5	1.5	2.5	2.5	2.5
Braking resistor cable mm ²		NA	2.5	2.5	4	4	1.5	1.5	2.5	2.5	2.5

Maximum Length of Motor Cables

Unscreened cable ⁽¹⁾	m	30	50	50	100	100	30	30	100	100	100
Screened cable	m	15	30	30	60	60	30	30	60	60	60

Related Fuse and MCB Sizes

MCB trip rating ⁽²⁾	A	6	6	10	10	20	6	6	6	10	10
MCB trip rating ⁽³⁾	A	6	10	16	20	32	6	6	10	16	16
Fuse rating ⁽²⁾	A	10	10	20	32	40	6	6	10	10	20
Fuse rating ⁽³⁾	A	10	10	20	32	40	6	6	10	10	20

(1) Not generally recommended. Refer to page 58.

(2) With DC reactor (3) Without DC reactor

NOTES

- 1 The above data is for guidance only. National and local regulations and guidelines should be strictly observed.
- 2 The above data applies only to installations NOT equipped with motor line reactors.
- 3 The length of motor cable may be extended by the installation of motor line reactors.
- 4 Longer cables **without** motor line reactors can be achieved by reducing the PWM carrier frequency, Function 12.
- 5 If the length of the motor cable is greater than 50m, it may be necessary to reduce the PWM carrier frequency, Function 12, to 0 to reduce the effect of leakage current.
- 6 Long cables may reduce the starting torque output of the motor due to voltage drop.
- 7 It is recommended that MICC-type cable is NOT used for motor supply due to high capacitance and thus greater limitation of maximum length.
- 8 The above data is based on the use of standard 4-pole squirrel cage induction motors.
- 9 If a non-standard motor is to be used, or cables in excess of 100m, consult IMO Precision Controls Ltd.
- 10 The figures given in the above table are proven lengths. Under certain operating conditions the maximum length may be considerably greater. If further assistance is required, please consult IMO Precision Controls Ltd.

Table of Heat Losses (Watts)

<i>Inverter type</i>	VXS...	20-1	40-1	75-1	150-1	220-1	40-3	75-3	150-3	220-3	400-3
		Single-phase Input					Three-phase Input				
Function 12 setting	Carrier freq. kHz	Heat Loss in Watts									
0	0.75	23	45	56	81	129	42	51	67	97	120
1	1.0	23	45	56	81	130	43	52	69	99	124
2	2.0	24	45	58	83	133	46	58	75	105	139
3	3.0	24	46	59	85	136	49	64	81	112	153
4	4.0	25	46	60	87	139	53	69	87	118	168
5	5.0	26	46	61	89	142	56	75	94	125	183
6	6.0	26	47	63	91	145	59	80	100	132	198
7	7.0	27	47	64	93	148	62	86	106	138	213
8	8.0	27	47	65	95	151	65	92	112	145	227
9	9.0	28	48	67	97	155	69	97	119	151	242
10	10.0	29	48	68	99	158	72	103	125	158	257
11	11.0	29	48	69	101	161	75	108	131	165	272
12	12.0	30	49	70	103	164	78	114	137	171	287
13	13.0	30	49	72	105	167	82	119	144	178	301
14	14.0	31	49	73	107	170	85	125	150	184	316
15	15.6	32	50	75	110	175	90	134	160	195	340

IMO JAGUAR DRIVES

5 YEAR WARRANTY

IMO JAGUAR drives are covered by a unique 5 year warranty against failure arising as a result of inferior material or workmanship.

In the event of a unit failing with 5 years of despatch from IMO, we will repair or replace the drive free of charge.

Whenever possible, in the interest of providing the fastest service to our customers, we will replace the failed drive with a new or service exchange unit at IMO's discretion. This may not be possible, however, if the failed unit is in poor condition owing to abuse or neglect. In such circumstances, the customer may elect to have the unit repaired within the warranty if viable, but physical refurbishment will be chargeable.

IMO will, upon request, provide a service exchange unit in advance of receipt of the failed unit if an order number is provided along with details of the failed unit. Replacements will be despatched at IMO's cost and credit will be issued upon receipt of the failed unit in good physical condition. Full credit will not be given if in IMO's judgment the unit has been physically or electrically abused. A no-fault-found charge will be levied upon units returned and found not to be faulty.

The terms of warranty do not provide for on-site service although a service engineer will be provided upon receipt of an order. IMO may elect to waive any charge should the findings on site indicate that any problem found lies within the scope of the warranty.

IMO Precision Controls Limited

Technical Helpline

Tel 0044(0)181 452 6444

8am to 6pm UK time Monday to Friday

Out-of-hours telephone contacts:

Technical Manager, Drives	(Mobile) 0831 207220
Product Support Engineer <i>UK North</i>	(Mobile) 0836 259108
Product Support Engineer <i>UK South</i>	(Mobile) 0831 207221